

# TRANSPORT DEPOT 7A-11 RACECOURSE RD, 5-9 FAUNCE ST & YOUNG ST, WEST GOSFORD STRUCTURAL DRAWINGS



## DRAWING LIST

- S1.01 COVER SHEET & DRAWING LIST
- S1.02 GENERAL NOTES - SHEET 1
- S1.03 GENERAL NOTES - SHEET 2
  
- S2.01 OVERALL SITE RETENTION PLAN
- S2.02 SHORING WALL RW No.01 PLAN - PART 1
- S2.03 SHORING WALL RW No.01 PLAN - PART 2
  
- S3.01 SHORING WALL RW No.01 ELEVATION - E01
- S3.02 SHORING WALL RW No.01 ELEVATION - E02
- S3.03 SHORING WALL RW No.01 ELEVATION - E03
- S3.04 SHORING WALL RW No.01 ELEVATION - E04
- S3.05 SHORING WALL RW No.01 ELEVATION - E05 PART 1
- S3.06 SHORING WALL RW No.01 ELEVATION - E05 PART 2
- S3.07 SHORING WALL RW No.01 ELEVATION - E06, E07 & E08
- S3.08 SHORING WALL RW No.01 ELEVATION - E09
- S3.09 SHORING WALL RW No.01 ELEVATION - E10
- S3.10 SHORING WALL RW No.01 CONSTRUCTION SEQUENCE
  
- S4.01 SHORING WALL SECTIONS
  
- S5.01 SHORING WALL DETAILS
  
- S6.01 RETAINING WALL PART PLAN
- S6.02 RETAINING WALL DETAILS - SHEET 1
- S6.03 RETAINING WALL DETAILS - SHEET 2

# GENERAL NOTES

## GENERAL

- G1. THESE DRAWINGS SHALL BE READ IN CONJUNCTION WITH ALL ARCHITECTURAL AND OTHER CONSULTANTS' DRAWINGS AND SPECIFICATIONS AND WITH SUCH OTHER WRITTEN INSTRUCTIONS AS MAY BE ISSUED DURING THE COURSE OF THE CONTRACT. ANY DISCREPANCY SHALL BE REFERRED TO THE ENGINEER BEFORE PROCEEDING WITH THE WORK.
- G2. ALL MATERIALS AND WORKMANSHIP SHALL BE IN ACCORDANCE WITH THE RELEVANT AND CURRENT STANDARDS AUSTRALIA CODES AND WITH THE BY-LAWS AND ORDINANCES OF THE RELEVANT BUILDING AUTHORITIES EXCEPT WHERE VARIED BY THE PROJECT SPECIFICATION.
- G3. ALL WORK IS TO BE CARRIED OUT IN ACCORDANCE WITH ALL WORKCOVER AND WORK HEALTH & SAFETY (ACT & REGULATION) REQUIREMENTS.
- G4. CONTRACT WORKS SHALL NOT COMMENCE UNTIL APPROVED BY RELEVANT AUTHORITIES.
- G5. WHERE EXISTING STRUCTURAL ELEMENTS ARE INDICATED TO BE RE-USED, TRIAXIAL CONSULTING ENGINEERS HAVE CONSIDERED THEIR ADEQUACY BASED ON REASONABLE ENGINEERING ASSESSMENT (I.E. EXCLUDING MATERIAL TESTING). THE CONTRACTOR IS TO ADVISE THE ENGINEER UPON DISCOVERY OF LATENT CONDITIONS WHEREBY EXISTING STRUCTURAL ELEMENTS DO NOT MEET STRUCTURAL REQUIREMENTS.
- G6. ALL DIMENSIONS SHOWN SHALL BE VERIFIED BY THE BUILDER ON SITE. ENGINEER'S DRAWINGS SHALL NOT BE SCALED FOR DIMENSIONS. ENGINEER'S DRAWINGS ISSUED IN ANY ELECTRONIC FORMAT MUST NOT BE USED FOR DIMENSIONAL SETOUT. REFER TO THE ARCHITECT'S DRAWINGS FOR ALL DIMENSIONAL SETOUT INFORMATION.
- G7. DURING CONSTRUCTION THE STRUCTURE SHALL BE MAINTAINED IN A STABLE CONDITION AND NO PART SHALL BE OVERSTRESSED. TEMPORARY BRACING SHALL BE DESIGNED & PROVIDED BY THE BUILDER TO KEEP THE WORKS AND EXCAVATIONS STABLE AT ALL TIMES.
- G8. UNLESS NOTED OTHERWISE ALL LEVELS ARE IN METRES AND ALL DIMENSIONS ARE IN MILLIMETRES.
- G9. THE STRUCTURAL COMPONENTS DETAILED ON THESE DRAWINGS HAVE BEEN DESIGNED IN ACCORDANCE WITH THE RELEVANT STANDARDS AUSTRALIA CODES AND LOCAL GOVERNMENT ORDINANCES FOR THE LOADINGS NOTED IN THE STRUCTURAL DESIGN CRITERIA.
- G10. NO CHANGES SHALL BE MADE WITHOUT THE WRITTEN CONSENT OF THE ENGINEER.
- G11. THE METHOD OF CONSTRUCTION AND THE MAINTENANCE OF SAFETY DURING CONSTRUCTION IS THE RESPONSIBILITY OF THE CONTRACTOR. IF ANY STRUCTURAL ELEMENT PRESENTS DIFFICULTY IN RESPECT OF CONSTRUCTABILITY OR SAFETY, THE MATTER SHALL BE REFERRED TO ENGINEER FOR RESOLUTION BEFORE PROCEEDING WITH THE WORK.
- G12. ALL WATERPROOFING TREATMENT MEMBRANES, FLASHING & WEEPHOLES SHALL BE TO THE ARCHITECTS OR MANUFACTURERS SPECIFICATIONS.
- G13. ALL ARCHITECTURAL FITMENTS (GLAZING, PARTITIONS, CEILINGS AND THE LIKE) SHALL ALLOW FOR SHORT AND LONG TERM MOVEMENTS OF THE STRUCTURE IN ACCORDANCE WITH THE LATEST REVISION OF AS/NZS 1170.0. THE BUILDER SHALL CONSULT TRIAXIAL CONSULTING ENGINEERS FOR THE EXTENT OF ALLOWANCE TO BE MADE.
- G14. ALL NON-LOAD BEARING ELEMENTS SHALL BE KEPT CLEAR OF THE STRUCTURE SOFFIT BY AN ALLOWANCE DETERMINED FROM SPAN/250 OR CANTILEVER/125 BUT NOT LESS THAN 20mm, UNLESS NOTED OTHERWISE ON THE DRAWINGS.
- G15. PROPRIETARY ITEMS SPECIFIED ON THE STRUCTURAL DRAWINGS SHALL BE INSTALLED STRICTLY IN ACCORDANCE WITH THE MANUFACTURER'S SPECIFICATIONS AND RECOMMENDATIONS.
- G16. ALL REQUIRED TESTS TO COMPLETE THE WORKS SHALL BE AT THE CONTRACTORS EXPENSE.
- G17. UNLESS THESE DRAWINGS ARE SPECIFICALLY LABELLED 'FOR CONSTRUCTION', THEY SHALL NOT BE USED FOR ANY CONSTRUCTION PURPOSES WITHOUT WRITTEN APPROVAL FROM TRIAXIAL CONSULTING ENGINEERS.
- G18. THE APPROVAL OF A SUBSTITUTION SHALL BE SOUGHT FROM THE ENGINEER BUT IS NOT AN AUTHORISATION FOR A VARIATION. ANY VARIATION INVOLVED MUST BE TAKEN UP THE WITH SUPERINTENDENT BEFORE THE WORK COMMENCES.
- G19. THE CONTRACTOR SHALL ALLOW IN TENDER FOR DETAILS NOT SHOWN ON THESE DRAWINGS BUT NECESSARY FOR COMPLETION OF THE CONTRACT.

## GENERAL (CONTINUED)

- G20. THE STRUCTURAL DRAWINGS DO NOT SHOW ALL DETAILS OF FIXTURES, INSERTS, OPENINGS, ETC. REQUIRED BY THE VARIOUS TRADES. ALL SUCH DETAILS, INCLUDING RECESSES AND CHASES, MUST BE APPROVED BY THE ENGINEER BEFORE PROCEEDING WITH CONSTRUCTION.
- G21. PROVIDE CLAY 'PLUG' TO ALL SERVICE TRENCHES WHERE ANY PIPE, DUCT OR CABLE ENTERS THE BUILDING TO PREVENT INGRESS OF WATER UNDER BUILDING.

## STRUCTURAL DESIGN CRITERIA

### PERMANENT & IMPOSED LOADING (AS1170.1)

#### LC1. LOADING BASED ON USAGE

AREA	IMPOSED LOAD (kPa)	SUPERIMPOSED PERMANENT LOAD (kPa)
LANDSCAPE	5.0	0.0
PAVEMENT	20.0	0.0
ROADWAY	20.0	0.0

## BULK EARTHWORKS

- BE1. ALL WORKMANSHIP AND MATERIALS SHALL BE IN ACCORDANCE WITH AS 3798 AND THE SPECIFICATION.
- BE2. GEOTECHNICAL INVESTIGATION BY STANTEC REPORT No. 300304375-400.1 DATED 22 SEPTEMBER 2023
- BE3. ORIGIN OF LEVELS ARE BASED ON AUSTRALIAN HEIGHT DATUM (AHD) UNLESS NOTED OTHERWISE.
- BE4. ALL TOPSOIL SHALL BE STRIPPED FROM THE CONSTRUCTION AREA AND STOCKPILED ON SITE TO BE LATER SPREAD AS DIRECTED.
- BE5. ALL BULK EARTHWORKS TO BE SETOUT FROM GRID LINES UNLESS NOTED OTHERWISE.
- BE6. ALL TEMPORARY BATTERS AT A SLOPE OF 1V:1H WITH MAXIMUM HEIGHT OF 1.5m AND AS PER GEOTECHNICAL ENGINEER'S INSTRUCTION.
- BE7. THE GEOTECHNICAL ENGINEER SHALL INSPECT ALL PHASES OF THE WORK TO DETERMINE WHETHER ADDITIONAL ROCK SUPPORT IS REQUIRED AND SHALL SPECIFY SUCH SUPPORT ON THE BASIS OF THE OBSERVED CONDITIONS.
- BE8. UNDER NO CIRCUMSTANCES SHALL ANY OF THE PILED SHORING WALL AND CAPPING BEAM BE DAMAGED DURING EXCAVATION. SHOULD ANY OF THE PILE SHORING WALL BE DAMAGED, THE ENGINEER SHALL BE NOTIFIED IMMEDIATELY FOR REMEDIATION.
- BE9. THE CONTRACTOR'S CHOICE OF PILING METHOD SHALL ENSURE THE PILE BORE IS MAINTAINED IN A STABLE CONDITION THROUGHOUT THE CONSTRUCTION PROCESS AND THE DESIGN TOE LEVELS CAN BE ACHIEVED.
- BE10. ALL EXISTING STRUCTURES, SERVICES AND UTILITIES ARE TO BE LOCATED BY THE CONTRACTOR PRIOR TO COMMENCEMENT OF ANY EARTHWORKS OR PILING. THE RESPONSIBILITY FOR LOCATION, AVOIDANCE AND WHERE NECESSARY, TEMPORARY PROTECTION, OF THESE EXISTING SERVICES IS THAT OF THE CONTRACTOR. ANY DAMAGE TO EXISTING STRUCTURES, SERVICES AND UTILITIES IS TO BE REPORTED TO THE ENGINEER IMMEDIATELY.

## FOUNDATIONS

- F1. GEOTECHNICAL INVESTIGATION REFER TO GEOTECHNICAL INVESTIGATION BY STANTEC REPORT No. 300304375-400.1 DATED 22 SEPTEMBER 2023
- F2. CERTIFICATION AND CLEANING  
1. ALL FOUNDATION MATERIAL AND BEARING CAPACITIES SHALL BE TESTED, APPROVED AND CERTIFIED BY A PRACTISING QUALIFIED GEOTECHNICAL ENGINEER.  
2. KEEP FOOTINGS DRY, CLEAN AND FREE OF LOOSE MATERIAL BEFORE INSPECTION, IMMEDIATELY PRIOR TO POURING CONCRETE AND DURING POURING.  
3. FOOTINGS ARE TO BE CONSTRUCTED AND POURED AS SOON AS POSSIBLE FOLLOWING EXCAVATION TO AVOID SOFTENING OR DRYING OUT BY EXPOSURE.
- F3. TESTING: THE FOLLOWING MINIMUM TESTING REQUIREMENTS ARE TO BE MET FOR THE FOUNDATIONS:  
\* VISUAL INSPECTION OF EVERY FOOTING BY GEOTECHNICAL ENGINEER.
- F4. ALL WALLS AND COLUMNS SHALL BE CONCENTRIC WITH SUPPORTING FOOTINGS UNLESS NOTED OTHERWISE.
- F5. FOOTING LEVELS WHERE SHOWN ARE FOR CONTRACT PURPOSES. ALL LEVELS TO BE VERIFIED ON SITE.
- F6. WHERE EXCAVATION WORK IS TO BE CARRIED OUT ADJACENT TO EXISTING FOOTINGS, THE EXACT LEVEL OF THE UNDERSIDE OF THE FOOTINGS SHALL BE DETERMINED PRIOR TO EXCAVATION TO ENSURE EXISTING FOOTINGS ARE NOT UNDERMINED.
- F7. WHERE VERIFIED FOUNDATION MATERIAL IS BELOW THE UNDERSIDE OF FOOTINGS AS DETAILED, BACKFILL ADDITIONAL EXCAVATION WITH CONCRETE MATCHING THE GRADE OF THE FOOTING TO A MINIMUM DEPTH OF 50mm UNO.
- F8. SIDES OF FOOTINGS SHALL BE FORMED AS NECESSARY WHEN EXCAVATED FACE IS NOT STABLE.
- F9. UNLESS APPROVED, EXCAVATIONS SHALL NOT EXTEND BELOW A LINE DIPPING AT 45° AND AWAY FROM THE NEAREST UNDERSIDE CORNER OF ANY FOOTING.

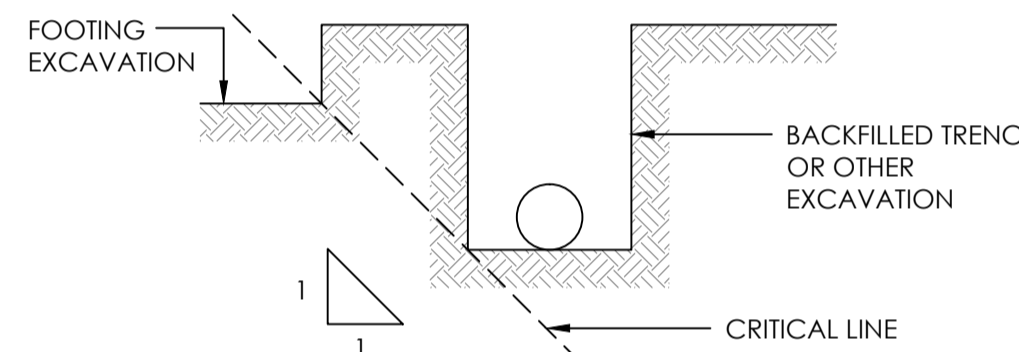

## PILING

- P1. ALL PILING TO COMPLY WITH AS 2159, AS3600 AND THE SPECIFICATION.
- P2. ALL PILE BORINGS ARE TO BE INSPECTED BY A QUALIFIED GEOTECHNICAL ENGINEER TO VERIFY DESIGN BEARING PRESSURES.
- P3. CONCRETE SHALL BE PLACED AS SOON AS POSSIBLE AFTER DRILLING AND AFTER APPROVAL HAS BEEN GIVEN BY THE SUPERINTENDENT. IF NECESSARY, TEMPORARY LINING SHALL BE USED TO MAINTAIN THE SIDES OF THE PILE UNTIL CONCRETING.
- P4. THE INSPECTION SHOULD ENSURE ADEQUATE ROUGHNESS IS ACHIEVED IN THE PILE SHAFT TO GUARANTEE SHAFT ADHESION. THE USE OF A ROUGHENING TOOL IS RECOMMENDED.
- P5. THE BASE OF THE PILE SHALL BE FOUNDED IN ORIGINAL UNDISTURBED MATERIAL IN ACCORDANCE WITH THE DESIGN. THE BASE SHALL BE CLEANED OUT OF ALL LOOSE AND DISTURBED MATERIAL PRIOR TO PLACING CONCRETE; CARE SHALL BE TAKEN TO PREVENT LOOSE SURFACE MATERIAL FALLING INTO THE HOLE.
- P6. THE PILE HOLES SHALL BE KEPT FREE OF WATER AT ALL TIMES BY BAILING AND PUMPING IF NECESSARY, PARTICULARLY PRIOR TO CONCRETING. CONCRETE SHALL NOT BE PLACED IN WATER. THE TOP OF THE HOLE SHALL BE PROPERLY COVERED TO PREVENT SURFACE WATER OR RAINFALL FROM ENTERING THE HOLE.
- P7. IF GROUNDWATER SEEPAGE INTO PILES IS PRESENT, WATER SHOULD BE PUMPED FROM THE PILES IMMEDIATELY PRIOR TO POURING CONCRETE. TREMIE METHODS SHOULD BE USED IF DEPTH OF WATER EXCEEDS 100mm. FULL HEIGHT TREMIE SHOULD BE USED FOR ALL PILES GREATER THAN 3M DEEP. CONCRETE MIX FOR TREMIE APPLICATION SHALL BE SUBMITTED FOR APPROVAL.
- P8. PROPER SAFETY PRECAUTIONS SHALL BE TAKEN TO AVOID INJURY TO PEOPLE. ANY UNATTENDED HOLES SHALL BE COVERED OR FENCED OFF AT ALL TIME.
- P9. WHERE THE FINAL CUT-OFF LEVEL IS ABOVE NATURAL GROUND LEVEL, THE PILES MUST BE FORMED TO THE CORRECT LEVEL BY USING TEMPORARY LINERS.
- P10. APPROPRIATE RECORDS SHALL BE TAKEN FOR EACH PILE AND SUBMITTED TO THE ENGINEER.
- P11. UNLESS SHOWN OTHERWISE, BORED PILES TO HAVE A MINIMUM SOCKET LENGTH OF 1 X PILE DIAMETER IN ROCK.
- P12. THE PLAN SET-OUT DIMENSIONS ARE AT PILE TRIM LEVEL. IF PILING AND DRIVING OF PILES TAKES PLACE FROM A DIFFERENT LEVEL, APPROPRIATE ADJUSTMENTS TO THE SET-OUT OF RAKING PILES, IF ANY, MUST BE MADE.
- P13. OBSTRUCTIONS INCLUDING EXISTING FOUNDATION PILES AND BASEMENT STRUCTURES MAY EXIST BENEATH THE GROUND SURFACE IN THE VICINITY OF THE PROPOSED WORKS. IF AN OBSTRUCTION HAS BEEN ENCOUNTERED AND THE DESIGN PILE OR ANCHOR LENGTH IS NOT ACHIEVED DUE TO PRACTICAL REFUSAL, THE ENGINEER SHALL BE NOTIFIED IMMEDIATELY. PRACTICAL REFUSAL IS DEEMED AS A SIGNIFICANT REDUCTION IN PENETRATION OF AN AUGER HEAD DURING PILING. IN SUCH CIRCUMSTANCES THE CONTRACTOR SHALL SEEK INSTRUCTIONS FROM THE ENGINEER.

## PILING (CONTINUED)

- P14. CONCRETE STRENGTH TO BE F'c = 32MPa, U.N.O.
- P15. COVER TO REINFORCEMENT TO BE 75mm U.N.O.
- P16. THE DRAWING SHOULD BE READ IN CONJUNCTION WITH THE SUPPLEMENTARY GEOTECHNICAL INVESTIGATION REPORT FOR METRO PROPERTY DEVELOPMENT BY GEOTECHNICAL CONSULTANTS AUSTRALIA (GCA) REPORT No. G2130-1, 25 MARCH 2021
- P17. UNDER NO CIRCUMSTANCES SHALL ANY OF THE LONGITUDINAL REINFORCEMENT BE CUT OR DAMAGED DURING CONSTRUCTION. SHOULD ANY OF THE LONGITUDINAL PILE REINFORCEMENT BE DAMAGED, THE ENGINEER SHALL BE NOTIFIED IMMEDIATELY FOR INSTRUCTIONS.
- P18. REFER TO SPECIFICATIONS FOR CONCRETE REQUIREMENTS.
- P19. PILE WALLS HAVE BEEN DESIGNED FOR 5.0KPA VERTICAL SURCHARGE.
- P20. REFER TO CONCRETE NOTES FOR REINFORCEMENT LAP LENGTHS.

## SHOTCRETE

- ST1. THE CONTRACTOR SHALL SUBMIT A METHOD STATEMENT FOR APPROVAL BY THE ENGINEER PRIOR TO COMMENCING THE WORKS.
- ST2. THE METHOD STATEMENT SHALL ADDRESS MIX DESIGN, QUALIFICATION AND EXPERIENCE OF OPERATORS, PLANT, SUBSTRATE PREPARATION AND SPRAYING PROCEDURE.
- ST3. ALL WORKMANSHIP AND MATERIALS SHALL BE IN ACCORDANCE WITH AS 3600, CIA Z5-1987, NSA CIA SPECIFICATION B82 AND OTHER RELEVANT AUSTRALIAN CODES.
- ST4. SHOTCRETE COMPONENTS AND QUALITY SHALL BE AS FOLLOWS.
- | ELEMENT        | STRENGTH GRADE | SLUMP (mm) | MAX. AGGREGATE (mm) | MIN. BINDER | AVERAGE BASE DRYING SHRINKAGE |
|----------------|----------------|------------|---------------------|-------------|-------------------------------|
| SHOTCRETE WALL | S32            | 60         | 10                  | *           | 750um                         |
- \* DENOTES EUCOSHOT B, OR APPROVED EQUIVALENT XYPEX C2000 TO MANUFACTURERS DETAILS. REBOUND 10%MAX.
- ST5. MIX PROPORTIONS SHALL BE DESIGNED BY THE CONTRACTOR AND SHALL BE TO THE APPROVAL OF THE ENGINEER. ALL CONCRETE SHALL BE PREMIXED AND DELIVERED TO SITE IN ACCORDANCE WITH AS 1379. WHERE ADMIXTURES ARE APPROVED BY THE ENGINEER FOR ADDITION TO THE MIX TO SPEED THE SETTING RATE OF THE CEMENT THE FOLLOWING SETTING TIMES AND STRENGTHS SHALL APPLY UNLESS OTHERWISE STATED:  
• INITIAL SET OF CEMENT/ADMIXTURE PASTE = 3 MINS  
• FINAL SET OF CEMENT/ADMIXTURE PASTE = 12 MINS.  
• 8 HOUR STRENGTH OF CONCRETE = 3 MPa  
• 24 HOUR STRENGTH OF CONCRETE = 10 MPa  
ALL CONSTITUENTS SHALL BE UNIFORMLY DISPERSED THROUGHOUT THE MIX.
- ST6. DEFINITIONS  
THE FOLLOWING DEFINITIONS EXPLAIN THE MEANINGS OF CERTAIN WORDS AND TERMS USED IN THIS SPECIFICATION  
SPRAYED CONCRETE IS A MIXTURE OF CEMENT AGGREGATE AND WATER PROJECTED AT A HIGH VELOCITY FROM THE NOZZLE INTO PLACE TO PRODUCE DENSE HOMOGENOUS MASS SHOTCRETE IS A TERM USED FOR SPRAYED CONCRETE WHERE THE MAXIMUM AGGREGATE SIZE IS NOT MORE THAN 20mm.  
REBOUND/GA TERM USED FOR ALL MATERIAL HAVING PASSED THROUGH THE NOZZLE WHICH DOES NOT CONFORM TO THE DEFINITION OF SPRAYED CONCRETE  
NOZZLE IS THE ATTACHMENT AT THE END OF THE MATERIAL HOSE FROM WHICH THE MATERIAL IS JETTED AT HIGH VELOCITY. NOZZLE MAN IS THE WORKMAN WHO MANIPULATES THE NOZZLE, CONTAINS THE CONSISTENCY, AND MAKES THE FINAL DISPOSITION OF THE MATERIAL.
- ST7. QUALIFICATIONS OF OPERATORS  
ALL OPERATORS SHALL BE TO THE APPROVAL OF THE ENGINEER. PRIOR TO COMMENCEMENT OF SPRAYING THE CONTRACTOR SHALL CERTIFY TO THE ENGINEER THAT THE FOREMAN, NOZZLEMAN, AND DELIVERY EQUIPMENT OPERATIVES HAVE COMPLETED SATISFACTORY WORK IN SIMILAR CAPACITIES ELSEWHERE. WHERE REQUIRED BY THE ENGINEER THE OPERATOR SHALL SPRAY PRECONSTRUCTION PANELS WHICH SHALL BE APPROVED BY THE ENGINEER BEFORE THE OPERATORS ARE EMPLOYED ON THE WORKS. SUCH PANELS MAY ALSO BE USED BY THE ENGINEER TO ASSESS THE COMPETENCE OF OPERATORS OR TRAINEES FOR WHOM SUCH CERTIFICATION IS NOT AVAILABLE.
- ST8. SUBSTRATE PREPARATION  
THE SURFACE SHALL BE COMPACT, TRIMMED AND GRADED AS REQUIRED AND DAMP BEFORE THE APPLICATION OF THE SPRAYED CONCRETE. NATURAL SURFACES SHALL MUST BE SUFFICIENTLY COHESIVE TO PREVENT EROSION WHEN THE SPRAYED CONCRETE IS APPLIED.
- ST9. SPRAYING PROCEDURE  
NO CONCRETE SHALL BE SPRAYED IN AIR TEMPERATURE LESS THAN 1 DEGREE (1°) CELSIUS. FRESHLY SPRAYED CONCRETE SHALL BE PROTECTED FROM RAIN OR WATER UNTIL THE SURFACE IS OF SUFFICIENT HARDNESS TO PREVENT DAMAGE  
SPRAYING SHALL BE DISCONTINUED IF WIND OR AIR CURRENTS CAUSE SEPARATION OF THE NOZZLE STREAM DURING PLACEMENT DURING STARTING OR STOPPING OF THE SPRAYED OPERATION OR WHENEVER SPRAYING IS IRREGULAR THE NOZZLE SHALL BE DIRECTED AWAY FROM THE WORKS ALL CORNERS AND ANY AREAS WHERE REBOUND CANNOT ESCAPE OR BE BLOWN FREE SHALL BE FILLED PRIOR TO GENERAL SPRAYING REBOUND SHALL NOT BE WORKED INTO THE CONSTRUCTION OR RE-USED IN THE WORKS. GUIDES SHALL BE SET UP TO ESTABLISH FINISHED SURFACES THESE GUIDES SHALL BE TO THE APPROVAL OF THE ENGINEER PRIOR TO SPRAYING. SPRAYED CONCRETE SHALL BE APPLIED SO THAT IT NEITHER SAGS NOR SLUMPS. SPRAYED CONCRETE SHALL BE TROWELLED TO A SMOOTH SURFACE. MAXIMUM DEVIATION FROM A 1m STRAIGHT EDGE SHALL BE 10 mm FULL RECORDS OF ALL MATERIALS DELIVERED TO THE SPRAYED CONCRETE MIXER SHALL BE KEPT AND MADE AVAILABLE TO THE CONSTRUCTION MANAGER.
- ST10. THE SHOTCRETE INFILL PANELS SHALL BE APPLIED PROGRESSIVELY AS EXCAVATION PROCEEDS, AT VERTICAL LIFTS OF APPROXIMATELY 1.8m. FOR STABILITY OF THE TOP LAYER OF SANDY FILL BETWEEN SOLDIER PIERS, RETAINED SOIL SHALL BE INSPECTED BY THE GEOTECHNICAL ENGINEER AND TEMPORARY STABILISED BY INSERTING 200 x 100 F11 TIMBER SLEEPER IN BETWEEN BACK OF PIER PRIOR TO SHOTCRETE.

## SHOTCRETE (CONTINUED)

- ST11. JOINTS  
THE POSITION AND TYPE OF ALL CONSTRUCTION JOINTS SHALL BE APPROVED BY THE ENGINEER.
- ST12. QUALITY CONTROL  
TESTING OF SHOTCRETE SHALL BE CARRIED OUT IN ACCORDANCE WITH THE SPRAYED CONCRETE MANUAL, CLAUSE A12, 'RECOMMENDED PRACTICE SPRAYED CONCRETE' PREPARED BY THE CONCRETE INSTITUTE OF AUSTRALIA.

ISSUED FOR CLIENT REVIEW	07.02.24	A	S.S.
AMENDMENTS	DATE	ISSUE	BY
<b>NOT FOR CONSTRUCTION</b>			

NORTH POINT U.N.O.	ARCHITECT
--------------------	-----------

CLIENT	PROJECT
AT&L AND ASSOCIATES	TRANSPORT DEPOT 7A-11 RACECOURSE RD, 5-9 FAUNCE ST & YOUNG ST, WEST GOSFORD
DESIGNED RO.O.	DRAWN S.S.
DATE 18.03.24	SIZE A1
CAD REF TX17790.00 - 501	

1300 874 294   TRIAXIAL.AU	SUITE 12, LEVEL 14, 327 PITT STREET, SYDNEY NSW 2000	PO BOX A203, SYDNEY SOUTH NSW 1235
<b>TRIAXIAL CONSULTING</b>	COMPLEX PROBLEMS RESOLVED SIMPLY	TO BE PRINTED IN COLOUR



DRAWING TITLE	GENERAL NOTES SHEET 1
PROJECT No.	TX17790.00 - S1.02
DRAWING No.	S1.02
ISSUE	A

PROJECT No.	TX17790.00 - S1.02
DRAWING No.	S1.02
ISSUE	A

# GENERAL NOTES

## SHORING NOTES

- SH1. ROCK LEVELS WHICH HAVE BEEN PROVIDED ARE INDICATIVE AND EXTRAPOLATED FROM THE GEOTECHNICAL REPORT.
- SH2. REFER TO THE GEOTECHNICAL REPORT FOR A DETAILED DESCRIPTION OF ANTICIPATED STRATA.
- SH3. IT IS THE SUBCONTRACTOR'S RESPONSIBILITY TO ENSURE THAT ALL SHORING WALLS INSTALLED DO NOT DAMAGE ADJACENT STRUCTURES OR SERVICES.
- SH4. A VIBRATION & MOVEMENT MONITORING PLAN MUST BE PREPARED AND MONITORING RESULTS ARE TO BE REPORTED REGULARLY TO THE MANAGING CONTRACTOR.
- SH5. WHERE MONITORING RESULTS ARE BEYOND ACCEPTABLE CRITERIA, AS OUTLINED WITHIN THE ENGINEERING DOCUMENTS, THE ENGINEER SHALL BE ADVISED IMMEDIATELY.
- SH6. THE SUBCONTRACTOR'S GEOTECHNICAL ENGINEER SHALL ADVISE ON ALLOWABLE TEMPORARY BATTER ANGLES AS EXCAVATION PROCEEDS.
- SH7. NOTIFY THE ENGINEER IF ANY REINFORCED PILE IS DAMAGED IN ANY WAY.
- SH8. REFER TO THE RELEVANT SERVICE CONSULTANT'S DRAWINGS FOR SIZE AND POSITION OF ALL SERVICE PENETRATIONS. UNLESS DIRECTED BY THE HEAD CONTRACTOR.
- SH9. THE PRESENCE OF UNCONTROLLED FILL (REFER SOILS REPORT) MAY CONTAIN ELEMENTS WHICH WILL NEED TO BE REMOVED AND REPLACED BEFORE SHORING INSTALLATION CAN PROCEED.
- SH10. THE SHORING CONTRACTOR SHALL PROVIDE AS-BUILT DRAWINGS OF THE SHORING WALLS FOR THE ANCHORING SUBCONTRACTOR'S USE IN PREPARING THE ANCHOR SETOUT SHOP DRAWINGS. THE AS-BUILT DRAWINGS ARE TO BE PROVIDED WITHIN 2 WEEKS OF COMPLETION OF SHORING AND ARE TO CONTAIN ALL INFORMATION AS DESCRIBED IN THE SPECIFICATION. ALL RECORDS ARE TO BE SUBMITTED BEFORE EXCAVATION PROCEEDS.
- SH11. AN ENCROACHMENT SURVEY INCLUDING FOOTING TEST PITS IS TO BE CARRIED OUT PRIOR TO SHORING INSTALLATION.
- SH12. THE SHORING CONTRACTOR IS TO CONFIRM CLEARANCE AND TOLERANCE REQUIREMENTS.
- SH13. REFER GEOTECHNICAL REPORT FOR ACTUAL ROCK TYPES AND DESCRIPTION TO JUDGE EASE OF EXCAVATION.
- SH14. IT IS THE SUBCONTRACTOR'S RESPONSIBILITY TO ENSURE THAT EXCAVATION STAGING ACROSS THE SITE DOES NOT OVERLOAD ANY STRUCTURAL MEMBER TO BOTH THE EXISTING SURROUNDING STRUCTURES AND THE NEW STRUCTURE BEING CONSTRUCTED.

## SHORING ANCHOR NOTES

- SA1. ANCHORS ARE PERMANENT UNLESS NOTED OTHERWISE AND ARE TO BE DESIGNED, SUPPLIED, INSTALLED, TESTED, CERTIFIED AND GUARANTEED BY A SPECIALIST CONTRACTOR WITH A PROVEN RECORD IN THIS TYPE OF WORK IN ACCORDANCE WITH THIS SPECIFICATION AND BS8081.
- SA2. THE ANCHORS ARE TO BE INSTALLED SUCH THAT THEIR ULTIMATE CAPACITY IS TWICE THE SAFE WORKING LOAD SHOWN ON THE DRAWINGS FOR PERMANENT ANCHORS AND 1.6 TIMES FOR TEMPORARY ANCHORS.
- SA3. THE DESIGN AND DETAILING ARE TO INCLUDE (BUT ARE NOT LIMITED TO) THE LENGTH OF ANCHOR, SIZE AND TYPE OF STRAND, CORROSION PROTECTION, GROUTING, STRESSING SEQUENCE, CAP PLATE, SHEATH AND ANCHORAGE DETAILS. TRIAXIAL CONSULTING ARE TO REVIEW AND COORDINATE WITH CONSULTANT ANCHOR DOCUMENTATION PRIOR TO CONSTRUCTION.
- SA4. THE CONTRACTOR SHALL MAINTAIN A LOG WHICH RECORDS FOR EACH GROUND ANCHOR, DATE HOLE DRILLED AND TOTAL ANCHOR LENGTH, DATE GROUTED AND GROUTED LENGTH, DATE OF SECONDARY GROUTING AND THE DATE OF EACH STRESSING OR CHECK-STRESSING OPERATION, AND THE LOADS IN THE GROUND ANCHOR BEFORE AND AFTER EACH CHECK STRESS.
- SA5. TESTING OF THE PERMANENT ANCHORS SHALL BE SPECIFIED BY THE CONTRACTOR TO SATISFY THEMSELVES OF THE ADEQUACY OF THE ANCHORS.
- SA6. GROUND ANCHORS SHALL CONSIST OF LOW RELAXATION 12.5mm DIAMETER SUPER GRADE STEEL STRANDS IN ACCORDANCE WITH AS1320 TO AS1313.
- SA7. ANCHORAGES SHALL BE IN ACCORDANCE WITH AS1314. AT ALL TIMES SUFFICIENT STRAND SHALL BE LEFT PROJECTING TO ENSURE THAT THE LOAD IN THE ANCHOR CAN BE INCREASED AND THAT THE ANCHOR CAN BE DESTRESSED. THIS PROJECTION SHALL NOT BE REMOVED UNTIL APPROVED IN WRITING BY THE ENGINEER.
- SA8. ON COMPLETION OF ANCHOR INSTALLATION, THE BUILDER IS TO CERTIFY THAT ALL TEMPORARY ANCHORS HAVE BEEN INSTALLED TO SATISFY SPECIFIED PERFORMANCE REQUIREMENTS AND LOAD CAPACITIES.
- SA9. ALL ANCHORS, BOLTS AND NAILS SHALL BE LOCATED SO AS TO AVOID ADJACENT PROPERTY STRUCTURES, ALL SERVICES AND PITS ETC. THE CONTRACTOR IS TO DETERMINE THE LOCATION OF ALL SERVICES ETC PRIOR TO INSTALLATION OF ANCHORS.
- SA10. PROOF OF SUITABILITY OF CORROSION PROTECTION IS TO BE SUPPLIED BY THE ANCHOR D&C CONTRACTOR. THE CORROSION PROTECTION SYSTEM IS TO BE ENCAPSULATED IN POLYETHYLENE SHEATHING OR BETTER.

## CONCRETE

- C1. ALL WORKMANSHIP AND MATERIAL SHALL BE IN ACCORDANCE WITH AS3600 CURRENT EDITION WITH AMENDMENTS, EXCEPT WHERE VARIED BY THE CONTRACT DOCUMENTS.
- C2. READYMIX CONCRETE SUPPLY SHALL COMPLY WITH AS1379.
- C3. CONCRETE QUALITY. ALL THE REQUIREMENTS OF THE ACSE SPECIFICATION DOCUMENT 1 (EDITION 6), SHALL APPLY TO THE FORMWORK, REINFORCEMENT AND CONCRETE UNLESS NOTED OTHERWISE. CONCRETE QUALITY SPECIFICATIONS AS SHOWN ON PLAN.
- C4. PROJECT CONTROL TESTING SHALL BE CARRIED OUT IN ACCORDANCE WITH AS1379.
- C5. NO ADMIXTURES SHALL BE USED IN CONCRETE UNLESS APPROVED IN WRITING.
- C6. CLEAR CONCRETE COVER TO ALL REINFORCEMENT FOR DURABILITY SHALL BE AS PER CONCRETE COVER SCHEDULE UNLESS SHOWN OTHERWISE.
- C7. DURABILITY REQUIREMENTS FOR CONCRETE.
- | EXPOSURE CLASS. TO AS3600: | MINIMUM CEMENT CONTENT: | MAXIMUM W/C RATIO: |
|----------------------------|-------------------------|--------------------|
| A1 & A2                    | -                       | 0.56               |
| B1                         | 320                     | 0.56               |
| B2                         | 390                     | 0.46               |
| C                          | 450                     | 0.40               |
- C8. ALL REINFORCEMENT SHALL BE FIRMLY SUPPORTED ON MILD STEEL PLASTIC TIPPED CHAIRS, PLASTIC CHAIRS OR CONCRETE CHAIRS AT 1m MAX. CENTRES. BOTH WAYS U.N.O. BARS SHALL BE TIED AT ALTERNATE INTERSECTIONS. USE PLASTIC CHAIRS IN EXPOSURE CONDITION GREATER THAN B1. MINIMUM BAR CHAIR SPACING FOR MESH REINFORCEMENT SHALL BE:
- |                           |          |
|---------------------------|----------|
| SL92, SL102, SL81, RL918: | 900 CTS. |
| SL72, SL82, RL818:        | 600 CTS. |
- C9. NO HOLES, CHASES OR EMBEDMENT OF PIPES OTHER THAN THOSE SHOWN ON THE STRUCTURAL DRAWINGS SHALL BE MADE IN CONCRETE MEMBERS WITHOUT THE PRIOR WRITTEN APPROVAL OF THE ENGINEER.
- C10. CONSTRUCTION JOINTS WHERE NOT SHOWN SHALL BE LOCATED TO THE APPROVAL OF THE ENGINEER.
- C11. ALL CONCRETE SHALL BE COMPACTED WITH MECHANICAL VIBRATORS.
- C12. THE ENGINEER SHALL BE GIVEN 48 HOURS NOTICE FOR REINFORCEMENT INSPECTIONS AND CONCRETE SHALL NOT BE DELIVERED UNTIL ENGINEERS APPROVAL IS OBTAINED.
- C13. WELDING OF REINFORCEMENT SHALL NOT BE PERMITTED UNLESS SHOWN ON THE STRUCTURAL DRAWINGS OR APPROVED BY THE ENGINEER.
- C14. REINFORCEMENT BARS AND LIGATURES:
- N\_ HOT ROLLED DEFORMED BAR, GRADE 500 NORMAL DUCTILITY AS4671-DN500N
  - R\_ HOT ROLLED ROUND BAR, GRADE 250 NORMAL DUCTILITY AS4671-R250N
  - W\_ COLD DRAWN ROUND WIRE, GRADE 500 LOW DUCTILITY AS4671-R500L
  - S\_ POOL STEEL HOT ROLLED DEFORMED BAR, GRADE 250 NORMAL DUCTILITY AS4671-D250N
- NOTE:** THE UNDERSCORE REPRESENTS NOMINAL BAR DIAMETER IN ACCORDANCE WITH AS4671
- REINFORCEMENT FABRIC:
- SL\_ SQUARE MESH, COLD DRAWN RIBBED WIRE GRADE 500, LOW DUCTILITY AS4671-D500L
  - RL\_ RECTANGULAR MESH, COLD DRAWN RIBBED WIRE GRADE 500, LOW DUCTILITY AS4671-D500L
  - \_L\_IM TRENCH MESH, COLD DRAWN RIBBED WIRE GRADE 500, LOW DUCTILITY AS4671-D500L
- NOTE:** THE UNDERSCORE REPRESENTS VARYING SPECIFICATIONS IN ACCORDANCE WITH AS467
- C15. REINFORCEMENT IS REPRESENTED DIAGRAMMATICALLY AND NOT NECESSARILY IN TRUE PROJECTION.
- C16. SPLICES IN REINFORCEMENT SHALL BE MADE ONLY IN POSITIONS SHOWN OR OTHERWISE APPROVED IN WRITING BY THE ENGINEER. LAPS SHALL BE IN ACCORDANCE WITH AS3600 AND NOT LESS THAN THE DEVELOPMENT LENGTH FOR EACH BAR.

- C17. STANDARD LAP AND COG LENGTHS UNLESS NOTED OTHERWISE ON DRAWINGS:
- | BAR DIAMETER | MIN. LAP LENGTH (mm) | MIN. COG LENGTH (mm) |
|--------------|----------------------|----------------------|
| N12          | 500                  | 180                  |
| N16          | 750                  | 210                  |
| N20          | 1000                 | 260                  |
| N24          | 1375                 | 310                  |
| N28          | 1560                 | 360                  |
| N32          | 1810                 | 400                  |
- C18. DEPTHS OF BEAMS ARE GIVEN FIRST AND INCLUDE SLAB THICKNESS.
- C19. CONCRETE SIZES DO NOT INCLUDE THICKNESSES OF APPLIED FINISHES.
- C20. REFER TO ARCHITECT'S DETAILS, FOR CHAMFERS, DRIP GROOVES, REGLETS, ETC., MAINTAIN COVER TO REINFORCEMENT AT THESE DETAILS.
- C21. USE ALIPHATIC ALCOHOLS SPRAYED OVER THE SURFACE PRIOR TO AND AFTER FINISHING TO REDUCE RATE OF EVAPORATION FROM THE SURFACE AND HELP CONTROL PLASTIC SHRINKAGE CRACKING. NOTE THAT THE USE OF ALIPHATIC ALCOHOLS IS NOT A SUBSTITUTE FOR CURING.
- C22. COMMENCE CURING OPERATIONS PROMPTLY AFTER SURFACE FINISHING IS COMPLETE. CURING COMPOUNDS ARE TO BE INSTALLED IN STRICT ACCORDANCE WITH MANUFACTURERS RECOMMENDATIONS AND ARE TO BE CHECKED FOR COMPATIBILITY WITH PROPOSED FLOOR FINISHES. SOME COMPOUNDS MAY REQUIRE REMOVAL FOR GLEUED DOWN FLOOR COVERINGS OR WET CURING AS DESCRIBED BELOW.
- C23. PROPPING WHICH SUPPORTS CONSTRUCTION OVER IS TO BE LEFT IN PLACE AS REQUIRED TO AVOID OVER STRESSING THE STRUCTURE DUE TO CONSTRUCTION LOADING.
- C24. CONDUITS, PIPES ETC. SHALL ONLY BE LOCATED IN THE MIDDLE ONE THIRD OF SLAB DEPTH AND SPACED AT NOT LESS THAN 3 DIAMETERS OF THE CONDUIT, PIPES ETC. PIPES OR CONDUITS SHALL NOT BE PLACED WITHIN THE COVER TO REINFORCEMENT.
- C25. MINIMUM MESH LAPS:

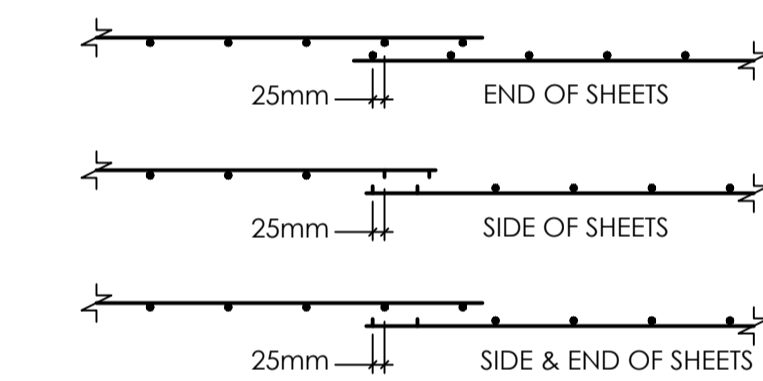

- C26. A 0.2mm POLYETHYLENE MEMBRANE SHALL BE CONTINUOUS UNDER SLAB LAPPED 200mm MIN. WHERE REQUIRED AND TAPED AT ALL SERVICE PENETRATIONS, LAPS AND PUNCTURES. THE MEMBRANE IS TO EXTEND UNDER AND TO THE SIDES OF SLABS, BEAMS AND THICKENINGS
- C27. SLAB REINFORCEMENT SHALL EXTEND AT LEAST 65mm ONTO MASONRY SUPPORT WALLS AND 50 PERCENT OF THE BOTTOM REINFORCEMENT SHALL BE COGGED TO ACHIEVE ANCHORAGE AT SIMPLY SUPPORTED ENDS.
- C28. WHERE TRANSVERSE TIE BARS ARE NOT SHOWN PROVIDE N12-400 SPLICED WHERE NECESSARY AND LAPPED 500mm WITH MAIN BARS.
- C29. UPWARD CAMBER TO FORMWORK OF REINFORCED CONCRETE CANTILEVERS SHALL BE L/120, WHERE L IS THE PROJECTION BEYOND FACE OF COLUMN OR WALL. CAMBER TO SUSPENDED SLABS AND BEAMS SHALL BE 5 FOR EVERY 2500 OF SPAN. MAINTAIN THE SLAB AND BEAM DEPTHS SHOWN.
- C30. SLABS AND BEAMS SHALL BE CONSTRUCTED TO BEAR ONLY ON THE BEAMS, WALLS, COLUMNS, ETC SHOWN ON THE DRAWINGS. TOPS OF LOAD BEARING MASONRY WALLS ARE TO BE TROWELLED SMOOTH AND 2 LAYERS OF ALCOR PROVIDED BETWEEN WALL AND SLAB. ALL OTHER BUILDING ELEMENTS SHALL BE KEPT 15mm MINIMUM CLEAR FROM SOFFITS OF THE STRUCTURE.

CONCRETE COVER SCHEDULE (mm)					
GRADE / USAGE	EXPOSED SURFACES			AGAINST GROUND	
	INTERIOR (A1/A2)	EXTERIOR (B1)	EXTERIOR (B2)	WITH D.P.M. (A1)	WITHOUT D.P.M. (A2)
20MPa	20(A1)/50(A2)	N/A	N/A	30	70
25MPa	20(A1)/30(A2)	60	N/A	30	50
32MPa	20(A1)/25(A2)	40	65	30	45
40MPa	20 (A1/A2)	30	45	30	40
RAFT SLABS	20 (A1/A2)	TOP - 40 SIDE - 50	50	30	50

## CONCRETE (CONTINUED)

## REINFORCED MASONRY

- GENERAL
- RM1. REINFORCED MASONRY SHALL COMPLY WITH THE REQUIREMENTS OF THE FOLLOWING STANDARDS, UNLESS NOTED OTHERWISE:-
- AS3700 MASONRY STRUCTURES
  - AS1012 METHOD OF TESTING CONCRETE
  - AS4671 STEEL REINFORCING MATERIALS
  - AS4455 MASONRY UNITS AND SEGMENTED PAVERS
  - AS4773 MASONRY IN SMALL BUILDINGS

- BLOCKS
- RM2. STRENGTH OF BLOCKS AND TYPE OF MORTAR SHALL BE AS FOLLOWS:

MATERIAL:	CHARACTERISTIC UNCONFINED COMPRESSIVE STRENGTH, F <sub>uc</sub> :	MORTAR CLASSIFICATION:
CONCRETE BLOCKS	15MPa	M3

- RM3. NO CHASES OR HOLES SHALL BE MADE WITHOUT PRIOR APPROVAL OF THE ENGINEER.
- RM4. CLEAN OUT PORTS SHALL BE PROVIDED FOR EACH POUR BY LEAVING OUT TWO UNITS AT THE BOTTOM OF EACH SECTION TO BE GROUTED. DURING WORK, MORTAR FINES AND ANY OTHER MATERIAL SHALL BE REMOVED FROM THE CAVITY GROUT SPACE. THE PORTS SHALL BE SEALED WITH SIMILAR MASONRY UNITS AFTER INSPECTION AND BEFORE GROUTING.

- JOINTS
- RM5. PROVIDE VERTICAL CONTROL JOINTS AT 8m MAX. CENTRES, AND 4m MAXIMUM FROM CORNERS IN ALL CONCRETE BLOCK WALLS UNLESS NOTED OTHERWISE.
- RM6. ALL MASONRY SHALL BE PROVIDED WITH ADDITIONAL VERTICAL JOINTS TO MATCH ALL JOINTS IN SUPPORTING OR SUPPORTED ELEMENTS.

- REINFORCEMENT
- RM7. REINFORCEMENT SYMBOLS:
- N DENOTES DEFORMED GRADE 500 NORMAL DUCTILITY CLASS BARS TO AS4671.
  - R DENOTES ROUND GRADE 250 NORMAL DUCTILITY CLASS BARS TO AS4671.
- RM8. ALL TIES AND REINFORCEMENT SHALL HAVE MIN. CLEAR COVER OF 50mm TO EXTERNAL FACE OF MASONRY.
- RM9. THE REINFORCING BARS MUST BE POSITIONED ACCURATELY AND TIED SECURELY TO THE STARTER BARS FROM THE PREVIOUS WALL LIFT OR FOOTING BEFORE PLACING GROUT. ADEQUATE LAP LENGTHS MUST BE MAINTAINED.
- RM10. BARS SHOWN ON THESE DRAWINGS SHALL BE CONTINUOUS OR HAVE LAP LENGTHS AS NOTED IN THE SPECIFICATION, REFER TO PLANS

- MORTAR
- RM11. MASONRY SHALL BE LAID WITH FULL HEAD AND BED MORTAR JOINTS. MORTAR FINES SHALL NOT PROTRUDE INTO CAVITY GROUT SPACE.
- RM12. MORTAR SHALL CURE FOR AT LEAST THREE DAYS BEFORE POURING CAVITY GROUT.
- GRROUTING
- RM13. READYMIX CONCRETE SUPPLY SHALL COMPLY WITH AS1379.
- RM14.
- RM15. CAVITY GROUT SHALL BE PLACED BY PUMPING OR OTHER APPROVED METHOD AND SHALL BE PLACED BEFORE INITIAL SET OCCURS, AND IN NO CASE MORE THAN 1.5 HOURS AFTER WATER IS ADDED.
- RM16. GROUTING SHALL BE DONE IN A CONTINUOUS POUR IN LIFTS SUITABLE FOR THE FLUIDITY OF GROUT (BUT NOT EXCEEDING 1200mm). IT SHALL BE CONSOLIDATED BY MECHANICAL VIBRATION OR RODDING WITH A ROD OF NOT LESS THAN 25mm DIAMETER DURING PLACING AND RECONSOLIDATED AFTER EXCESS MOISTURE HAS BEEN ABSORBED, BUT BEFORE PLASTICITY IS LOST.
- RM17. NO CAVITY OR CORE SHALL BE FILLED TO A HEIGHT GREATER THAN 1200mm WITHOUT SUITABLE SHORING.
- RM18. AFTER A WAITING PERIOD SUFFICIENT TO PERMIT THE GROUT TO BECOME PLASTIC BUT BEFORE IT HAS TAKEN ANY SET, THE SUCCEEDING LIFT SHALL BE POURED AN CONSOLIDATED WITH THE VIBRATOR OR ROD EXTENDING 450mm INTO THE PRECEDING LIFT.
- RM19. THE TOP LIFT SHALL BE RECONSOLIDATED AFTER A WAITING PERIOD AND ANY SPACE LEFT BY SHRINKAGE SHALL BE REFILLED BY GROUT.

ISSUED FOR CLIENT REVIEW  
AMENDMENTS

DATE	ISSUE	BY
07.02.24	A	S.S.

**NOT FOR CONSTRUCTION**

NORTH POINT U.N.O. ARCHITECT

CLIENT  
**AT&L AND ASSOCIATES**

PROJECT  
**TRANSPORT DEPOT**  
7A-11 RACECOURSE RD,  
5-9 FAUNCE ST & YOUNG ST, WEST GOSFORD

DESIGNED RO.O. DRAWN S.S. DATE 18.03.24 SIZE A1 CAD REF TX17790.00 - 501

**TRIAXIAL CONSULTING**  
1300 874 294 | TRIAXIAL.AU  
SUITE 12, LEVEL 14, 327 PITT STREET, SYDNEY NSW 2000  
PO BOX A203, SYDNEY SOUTH NSW 1235

COMPLEX PROBLEMS  
RESOLVED SIMPLY

**TO BE PRINTED IN COLOUR**

DRAWING TITLE  
**GENERAL NOTES SHEET 2**

PROJECT No. TX17790.00 - DRAWING No. S1.03 ISSUE A

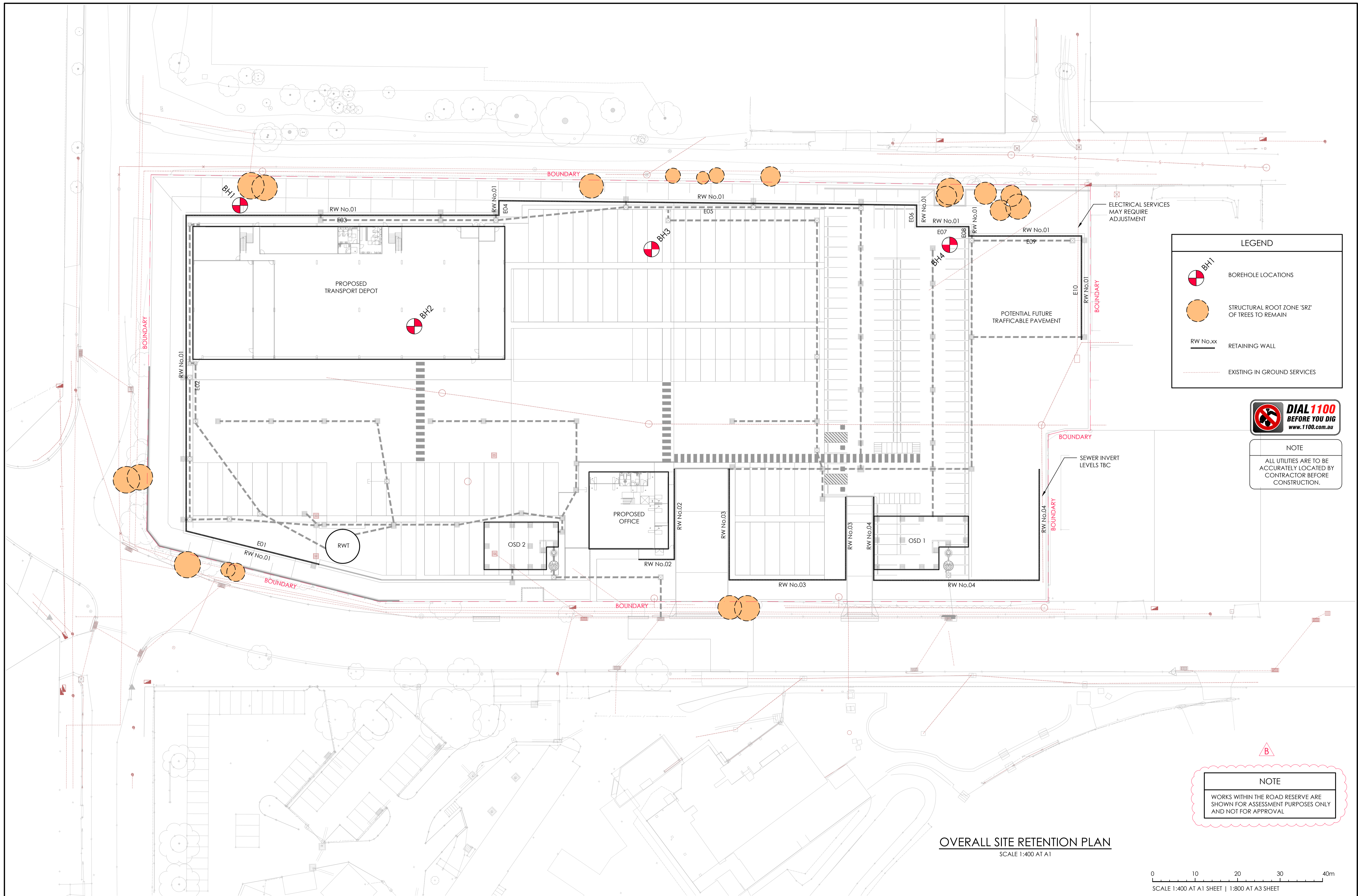

**LEGEND**

- Borehole Locations
- Structural Root Zone 'SRZ' of Trees to Remain
- Retaining Wall
- Existing in Ground Services



**NOTE**  
ALL UTILITIES ARE TO BE ACCURATELY LOCATED BY CONTRACTOR BEFORE CONSTRUCTION.

**NOTE**  
WORKS WITHIN THE ROAD RESERVE ARE SHOWN FOR ASSESSMENT PURPOSES ONLY AND NOT FOR APPROVAL

**OVERALL SITE RETENTION PLAN**  
SCALE 1:400 AT A1

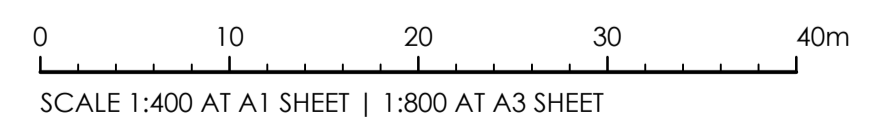

ISSUED FOR CLIENT REVIEW  
AMENDMENTS

18.03.24	B	S.S.
07.02.24	A	S.S.
DATE	ISSUE	BY

**NOT FOR CONSTRUCTION**

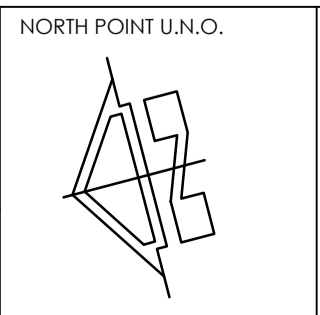

CLIENT  
**AT&L AND ASSOCIATES**

PROJECT  
**TRANSPORT DEPOT**  
7A-11 RACECOURSE RD,  
5-9 FAUNCE ST & YOUNG ST, WEST GOSFORD

DESIGNED RO.O.    DRAWN S.S.    DATE 18.03.24    SIZE A1    CAD REF TX17790.00 - S01



1300 874 294 | TRIAXIAL.AU  
SUITE 12, LEVEL 14, 327 PITT STREET, SYDNEY NSW 2000  
PO BOX A203, SYDNEY SOUTH NSW 1235  
**TO BE PRINTED IN COLOUR**

DRAWING TITLE  
**OVERALL SITE RETENTION PLAN**

PROJECT No. **TX17790.00 - S2.01**    DRAWING No.    ISSUE **B**

NOTE: PERMANENT ANCHORS WILL LIKELY BE REQUIRED TO BE INSTALLED OUTSIDE THE PROPERTY BOUNDARY. RELEVANT AUTHORITY APPROVALS WILL BE REQUIRED PRIOR TO CONSTRUCTION. A SEPARATE APPROVAL UNDER SECTION 138 OF THE ROADS ACT 1993 TO BE SORT FOR THIS WORK IF IT IS TO BE CARRIED OUT. INFORMATION ABOUT THE PERMANENT ANCHORS ARE SHOWN FOR ASSESSMENT PURPOSES ONLY, NOT FOR APPROVAL.

NOTE: GROUND ANCHORS MAY PENETRATE STRUCTURAL ROOT ZONE. PROJECT ARBORIST TO CONFIRM ADEQUACY. TYPICAL

COORDINATION REQUIRED IN ANCHOR LEVELS TO ENSURE NO CLASHES DURING INSTALLATION

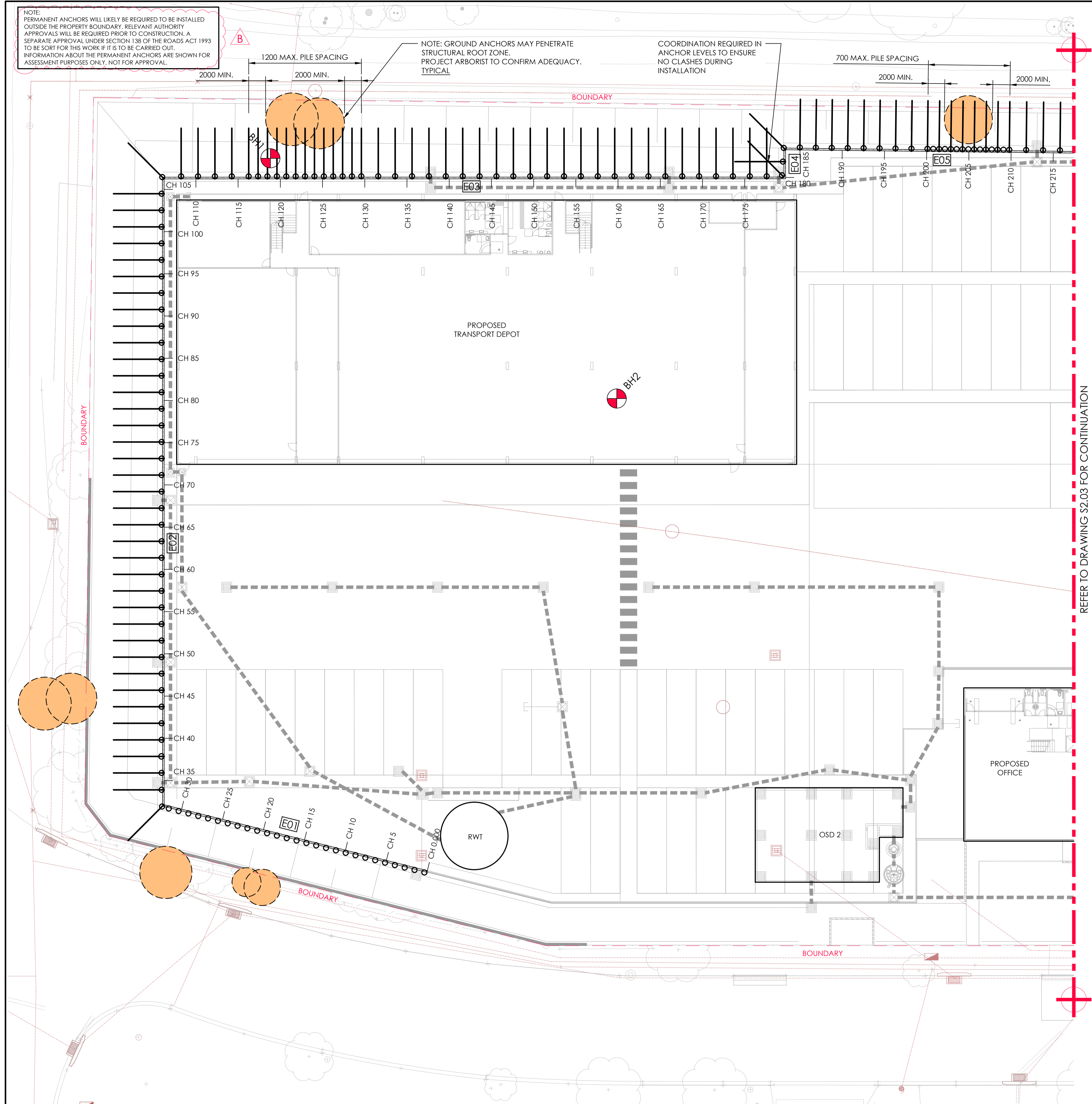

PILING SCHEDULE				
MARK	TYPE	SIZE (MINIMUM)	REINFORCEMENT	REMARKS
P1	PILE	600 DIAMETER	6-N24 LONGITUDINAL, N12-300 SPIRAL TIES	

CONCRETE QUALITY							
ELEMENT	AS3600 EXPOSURE CLASS.	AS1379 CONCRETE CLASS.	F <sub>c</sub> (MPa) CHARACTERISTIC COMPRESSIVE STRENGTH	CEMENT TYPE	ADMIXTURES	MAX. AGGREGATE SIZE (mm)	SLUMP
PILE	B1	N	32	GP	NIL	20	80
CAPPING BEAM	B1	N	32	GP	NIL	20	80
SHOTCRETE WALL	B1	N	32	GP	NIL	20	60

CONCRETE COVER SCHEDULE (mm)		
GRADE	ENVIRONMENT	
	EXPOSED SURFACES EXTERNAL (B1)	AGAINST GROUND WITHOUT D.P.M. (A2)
32MPa	40	65

**RETAINING WALL CLASSIFICATION**

STRUCTURE CLASSIFICATION IN ACCORDANCE WITH AS4678: CLASSIFICATION C  
 SITE FACTOR, S = 1.0  
 ACCELERATION COEFFICIENT, α = 0.08  
 EARTHQUAKE DESIGN CATEGORY: Ber

**DESIGN NOTES**

- DESIGN WORKING LIFE IS 50 YEARS.
- EXPOSURE CLASSIFICATION OF PILES IS MODERATELY AGGRESSIVE IN ACCORDANCE WITH AS2159 AND THE GEOTECHNICAL REPORT BY STANTEC.
- THIS SITE IS NOT LOCATED IN A KNOWN MINE SUBSIDENCE DISTRICT IN ACCORDANCE WITH THE NSW GOVERNMENT'S PLANNING PORTAL.

**LEGEND**

- BOREHOLE LOCATIONS
- STRUCTURAL ROOT ZONE 'SRZ' OF TREES TO REMAIN
- EXISTING IN GROUND SERVICES
- 600 DIA. REINFORCED CONCRETE SOLDIER PILE. REFER TO DETAILS
- SHORING ANCHORS TO D&C CONTRACTORS DETAILS

**NOTES**

- TRIAxIAL DESIGN DRAWINGS ARE NOT TO BE USED FOR SETOUT PURPOSES. TRIAXIAL DRAWINGS ARE TO BE USED FOR REFERENCE ONLY AND SHOULD BE READ IN CONJUNCTION WITH THE STRUCTURAL AND ARCHITECTURAL DRAWINGS.
- THE CONTRACTOR SHALL ENSURE A SERVICES SEARCH HAS BEEN CARRIED OUT, AND THAT ALL EXISTING STRUCTURES, SERVICES (INCLUDING REDUNDANT SERVICES) AND UTILITIES ARE LOCATED PRIOR TO COMMENCEMENT OF WORKS. THE ACCURACY OF THIS INFORMATION SHOULD BE VERIFIED AS NECESSARY BEFORE WORK COMMENCES ON SITE.
- THE CONTRACTOR TO REVIEW LOCATIONS OF SERVICES AND UTILITIES AND TO IMPLEMENT PROTECTION AND AVOIDANCE METHODS TO ENSURE NO DAMAGE OCCURS IN THE PROCESS OF CARRYING OUT THE WORKS.
- SHORING WALL DEFLECTION MONITORING REQUIREMENTS TO BE PROVIDED WITH FOR CONSTRUCTION STRUCTURAL DOCUMENTATION.
- WORKS WITHIN THE ROAD RESERVE ARE SHOWN FOR ASSESSMENT PURPOSES ONLY AND NOT FOR APPROVAL.

SHORING WALL RW No.01 PLAN  
 PART 1  
 SCALE 1:250 AT A1

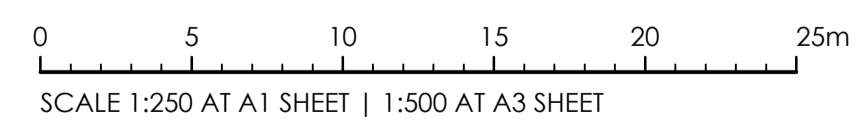

ISSUED FOR CLIENT REVIEW 18.03.24 B S.S.  
 ISSUED FOR CLIENT REVIEW 07.02.24 A S.S.  
 AMENDMENTS DATE ISSUE BY

**NOT FOR CONSTRUCTION**

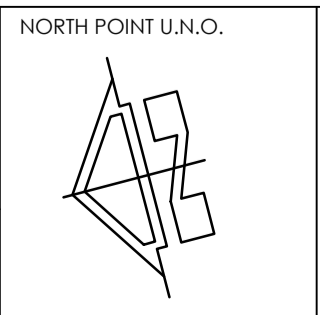

ARCHITECT  
 CLIENT  
**AT&L AND ASSOCIATES**

PROJECT  
**TRANSPORT DEPOT**  
 7A-11 RACECOURSE RD,  
 5-9 FAUNCE ST & YOUNG ST, WEST GOSFORD

DESIGNED RO.O. DRAWN S.S. DATE 18.03.24 SIZE A1 CAD REF TX17790.00 - 501



1300 874 294 | TRIAXIAL.AU  
 SUITE 12, LEVEL 14, 327 PITT STREET, SYDNEY NSW 2000  
 PO BOX A203, SYDNEY SOUTH NSW 1235

TO BE PRINTED IN COLOUR

DRAWING TITLE  
**SHORING WALL RW No.01 PLAN PART 1**

PROJECT No. TX17790.00 - S2.02 DRAWING No. ISSUE B

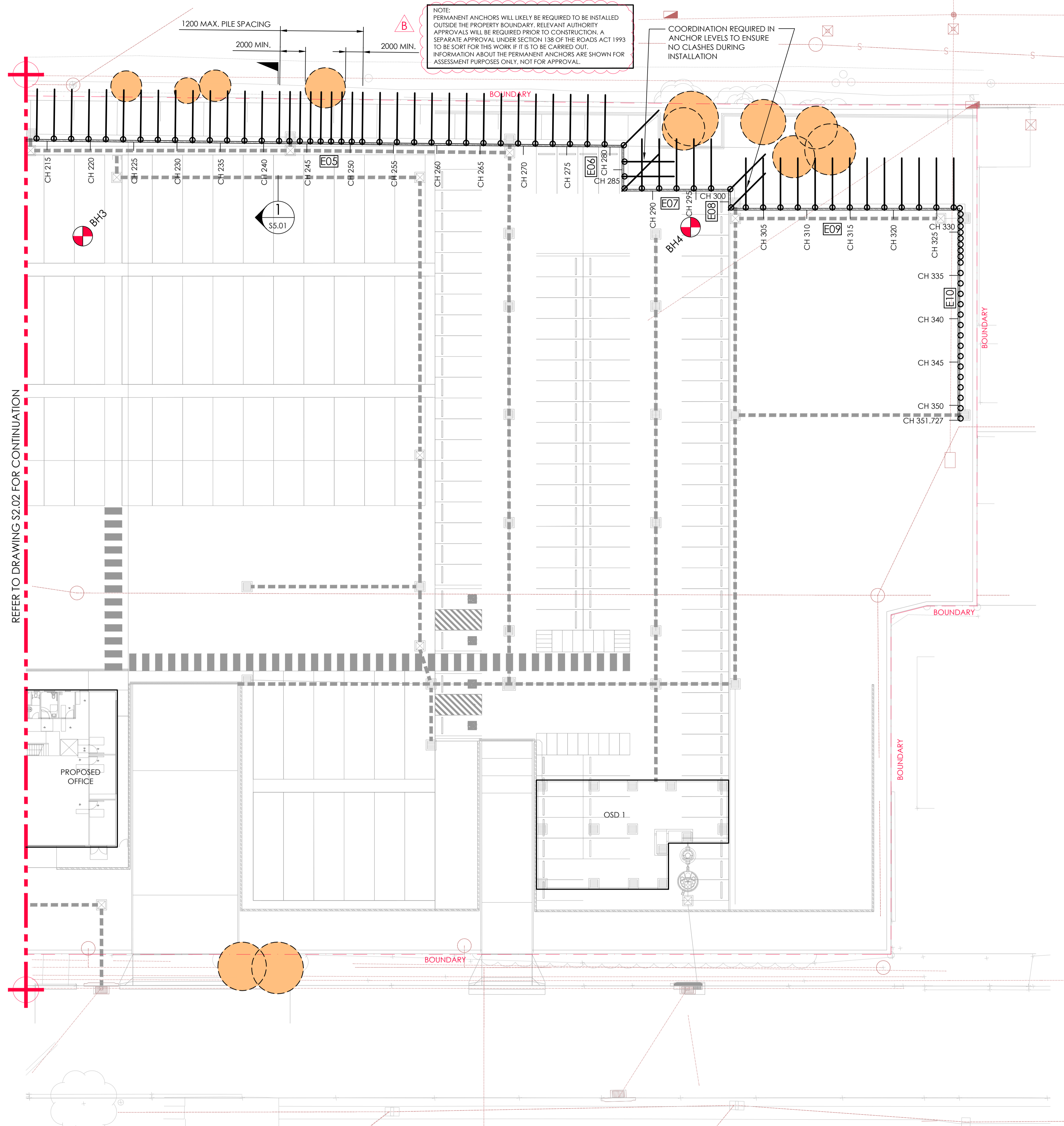

PILING SCHEDULE				
MARK	TYPE	SIZE (MINIMUM)	REINFORCEMENT	REMARKS
P1	PILE	600 DIAMETER	6-N24 LONGITUDINAL, N12-300 SPIRAL TIES	

CONCRETE QUALITY							
ELEMENT	AS3600 EXPOSURE CLASS.	AS1379 CONCRETE CLASS.	F <sub>c</sub> (MPa) CHARACTERISTIC COMPRESSIVE STRENGTH	CEMENT TYPE	ADMIXTURES	MAX. AGGREGATE SIZE (mm)	SLUMP
PILE	B1	N	32	GP	NIL	20	80
CAPPING BEAM	B1	N	32	GP	NIL	20	80
SHOTCRETE WALL	B1	N	32	GP	NIL	20	60

CONCRETE COVER SCHEDULE (mm)		
GRADE	ENVIRONMENT	
	EXPOSED SURFACES EXTERNAL (B1)	AGAINST GROUND WITHOUT D.P.M. (A2)
32MPa	40	65

**RETAINING WALL CLASSIFICATION**

STRUCTURE CLASSIFICATION IN ACCORDANCE WITH AS4678: CLASSIFICATION C  
 SITE FACTOR, S = 1.0  
 ACCELERATION COEFFICIENT, α = 0.08  
 EARTHQUAKE DESIGN CATEGORY: Ber

**DESIGN NOTES**

- DESIGN WORKING LIFE IS 50 YEARS.
- EXPOSURE CLASSIFICATION OF PILES IS MODERATELY AGGRESSIVE IN ACCORDANCE WITH AS2159 AND THE GEOTECHNICAL REPORT BY STANTEC.
- THIS SITE IS NOT LOCATED IN A KNOWN MINE SUBSIDENCE DISTRICT IN ACCORDANCE WITH THE NSW GOVERNMENT'S PLANNING PORTAL.

**LEGEND**



- BOREHOLE LOCATIONS
- STRUCTURAL ROOT ZONE 'SRZ' OF TREES TO REMAIN
- EXISTING IN GROUND SERVICES
- 600 DIA. REINFORCED CONCRETE SOLDIER PILE. REFER TO DETAILS
- SHORING ANCHORS TO D&C CONTRACTORS DETAILS

**NOTES**

- TRIAxIAL DESIGN DRAWINGS ARE NOT TO BE USED FOR SETOUT PURPOSES. TRIAXIAL DRAWINGS ARE TO BE USED FOR REFERENCE ONLY AND SHOULD BE READ IN CONJUNCTION WITH THE STRUCTURAL AND ARCHITECTURAL DRAWINGS.
- THE CONTRACTOR SHALL ENSURE A SERVICES SEARCH HAS BEEN CARRIED OUT, AND THAT ALL EXISTING STRUCTURES, SERVICES (INCLUDING REDUNDANT SERVICES) AND UTILITIES ARE LOCATED PRIOR TO COMMENCEMENT OF WORKS. THE ACCURACY OF THIS INFORMATION SHOULD BE VERIFIED AS NECESSARY BEFORE WORK COMMENCES ON SITE.
- THE CONTRACTOR TO REVIEW LOCATIONS OF SERVICES AND UTILITIES AND TO IMPLEMENT PROTECTION AND AVOIDANCE METHODS TO ENSURE NO DAMAGE OCCURS IN THE PROCESS OF CARRYING OUT THE WORKS.
- SHORING WALL DEFLECTION MONITORING REQUIREMENTS TO BE PROVIDED WITH FOR CONSTRUCTION STRUCTURAL DOCUMENTATION.
- WORKS WITHIN THE ROAD RESERVE ARE SHOWN FOR ASSESSMENT PURPOSES ONLY AND NOT FOR APPROVAL.

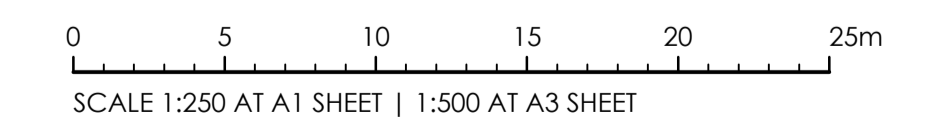
SHORING WALL RW No.01 PLAN  
 PART 2  
 SCALE 1:250 AT A1



LEGEND	
	APPROXIMATE LEVEL OF EXTREMELY WEATHERED MATERIAL
	APPROXIMATE LEVEL OF VERY LOW TO LOW STRENGTH BEDROCK
	PERMANENT SHORING ANCHOR

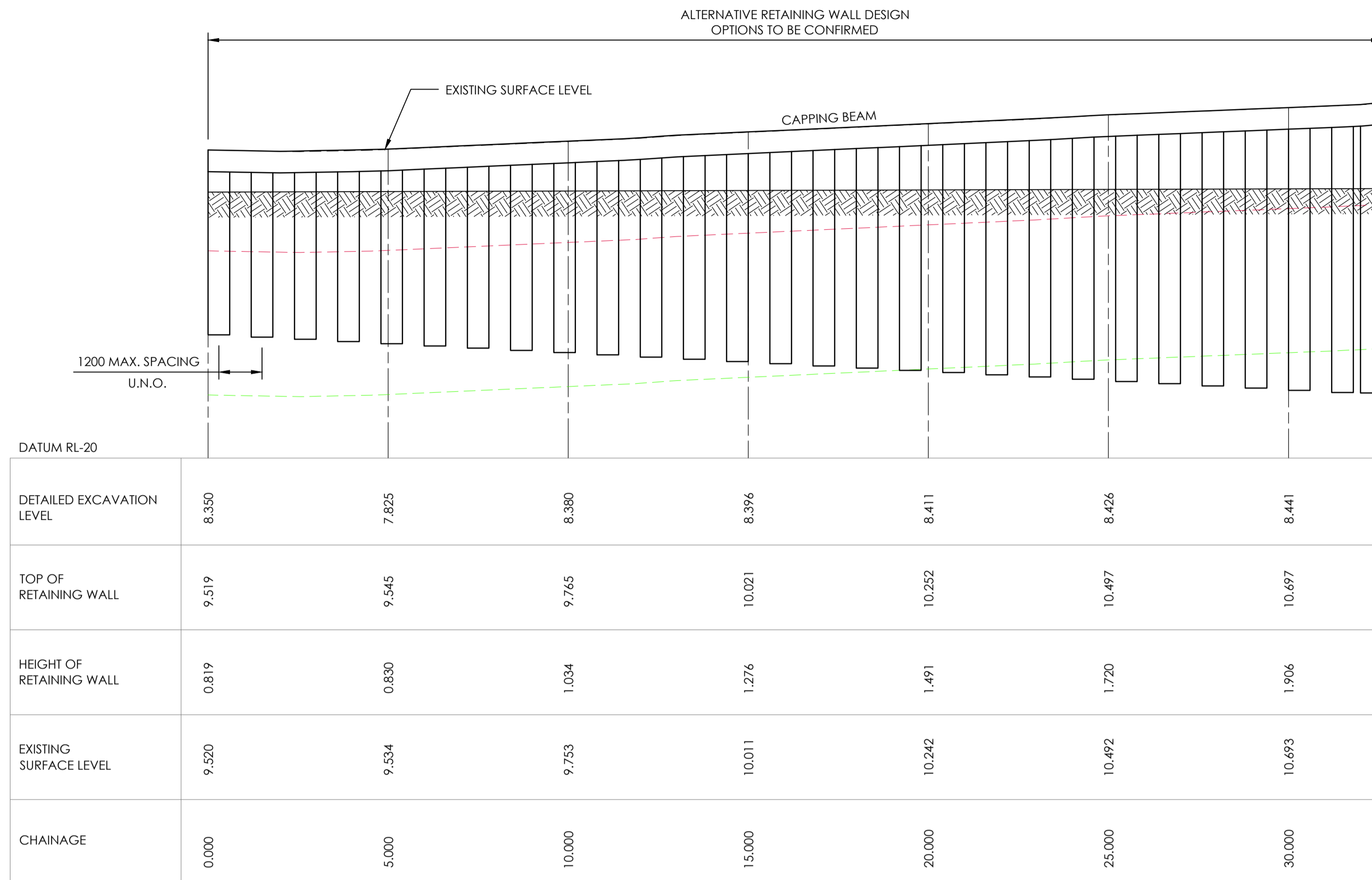

### SHORING WALL RW No.01 ELEVATION - E01

SCALE 1:100 AT A1

**NOTE**

AN ALLOWANCE OF 350mm FROM CIVIL 'BOTTOM OF RETAINING WALL' LEVELS HAS BEEN ALLOWED FOR IN THE CALCULATION OF BULK EXCAVATION LEVELS. CIVIL ENGINEER TO CONFIRM.

**NOTE**

WORKS WITHIN THE ROAD RESERVE ARE SHOWN FOR ASSESSMENT PURPOSES ONLY AND NOT FOR APPROVAL.

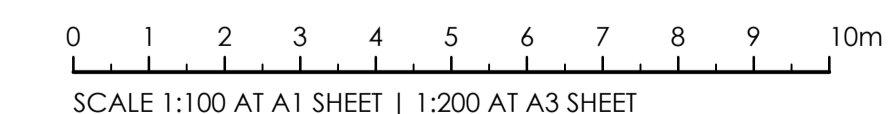

ISSUED FOR CLIENT REVIEW ISSUED FOR CLIENT REVIEW AMENDMENTS	18.03.24    B    S.S. 07.02.24    A    S.S. DATE    ISSUE    BY	NORTH POINT U.N.O. ARCHITECT	CLIENT <b>AT&amp;L AND ASSOCIATES</b>	PROJECT <b>TRANSPORT DEPOT</b> 7A-11 RACECOURSE RD, 5-9 FAUNCE ST & YOUNG ST, WEST GOSFORD	 <b>TRIAxIAL CONSULTING</b> 1300 874 294   TRIAXIAL.AU SUITE 12, LEVEL 14, 327 PITT STREET, SYDNEY NSW 2000 PO BOX A203, SYDNEY SOUTH NSW 1235 COMPLEX PROBLEMS RESOLVED SIMPLY	DRAWING TITLE <b>SHORING WALL RW No.01 ELEVATIONS - E01</b> PROJECT No. <b>TX17790.00 - S3.01</b> DRAWING No. <b>S3.01</b> ISSUE <b>B</b>
NOT FOR CONSTRUCTION				TO BE PRINTED IN COLOUR		

LEGEND	
	APPROXIMATE LEVEL OF EXTREMELY WEATHERED MATERIAL
	APPROXIMATE LEVEL OF VERY LOW TO LOW STRENGTH BEDROCK
	PERMANENT SHORING ANCHOR

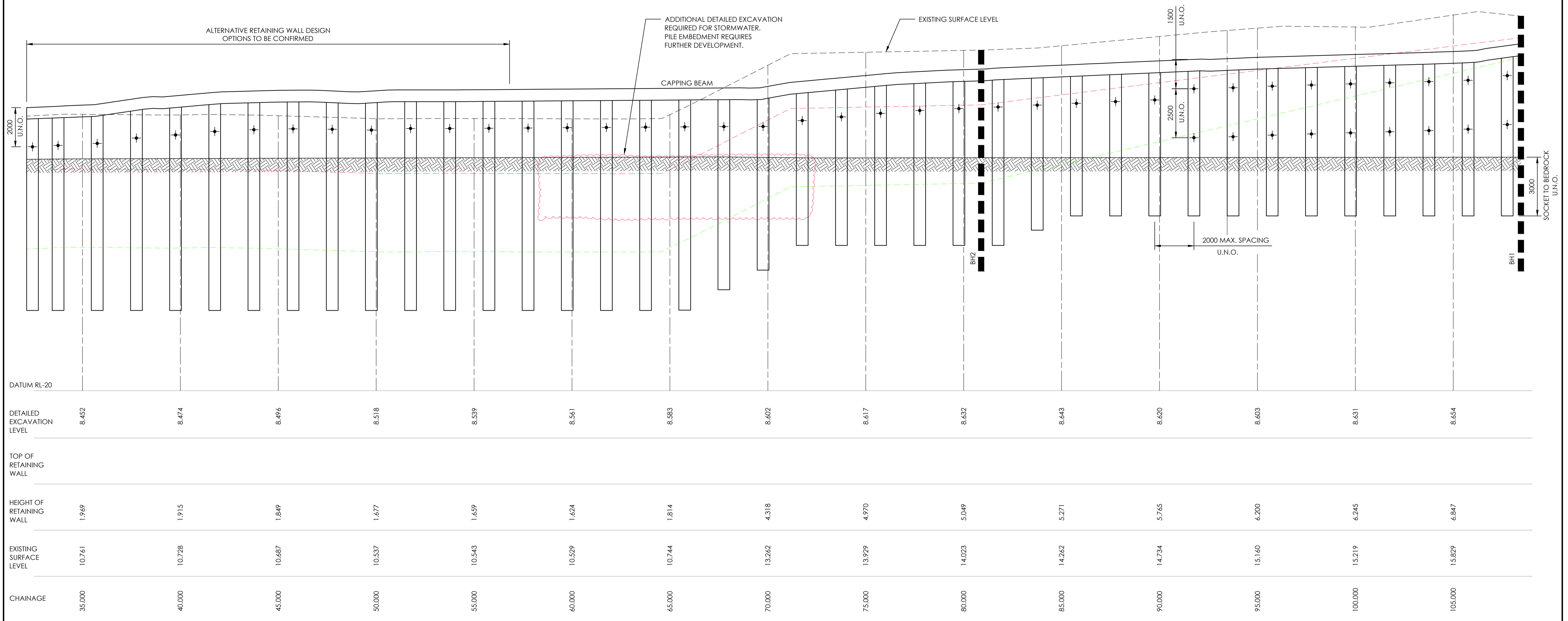

SHORING WALL RW No.01 ELEVATION - E02

SCALE 1:100 AT A1

**NOTE**  
 AN ALLOWANCE OF 350mm FROM CIVIL 'BOTTOM OF RETAINING WALL' LEVELS HAS BEEN ALLOWED FOR IN THE CALCULATION OF BULK EXCAVATION LEVELS. CIVIL ENGINEER TO CONFIRM.

**B** **NOTE**  
 WORKS WITHIN THE ROAD RESERVE ARE SHOWN FOR ASSESSMENT PURPOSES ONLY AND NOT FOR APPROVAL.

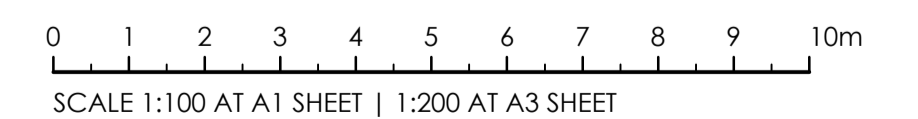

ISSUED FOR CLIENT REVIEW 18.03.24 B S.S.  
 ISSUED FOR CLIENT REVIEW 07.02.24 A S.S.  
 AMENDMENTS DATE ISSUE BY

**NOT FOR CONSTRUCTION**

NORTH POINT U.N.O.  
 ARCHITECT

CLIENT  
**AT&L AND ASSOCIATES**

PROJECT  
**TRANSPORT DEPOT**  
 7A-11 RACECOURSE RD,  
 5-9 FAUNCE ST & YOUNG ST, WEST GOSFORD

DESIGNED RO.O. DRAWN S.S. DATE 18.03.24 SIZE A1 CAD REF TX17790.00 - S01



**TRIAxIAL CONSULTING**  
 COMPLEX PROBLEMS  
 RESOLVED SIMPLY

1300 874 294 | TRIAXIAL.AU  
 SUITE 12, LEVEL 14, 327 PITT STREET, SYDNEY NSW 2000  
 PO BOX A203, SYDNEY SOUTH NSW 1235  
 TO BE PRINTED IN COLOUR

DRAWING TITLE  
**SHORING WALL RW No.01 ELEVATION - E02**

PROJECT No. **TX17790.00 - S3.02** DRAWING No. ISSUE **B**



LEGEND	
	APPROXIMATE LEVEL OF EXTREMELY WEATHERED MATERIAL
	APPROXIMATE LEVEL OF VERY LOW TO LOW STRENGTH BEDROCK
	PERMANENT SHORING ANCHOR

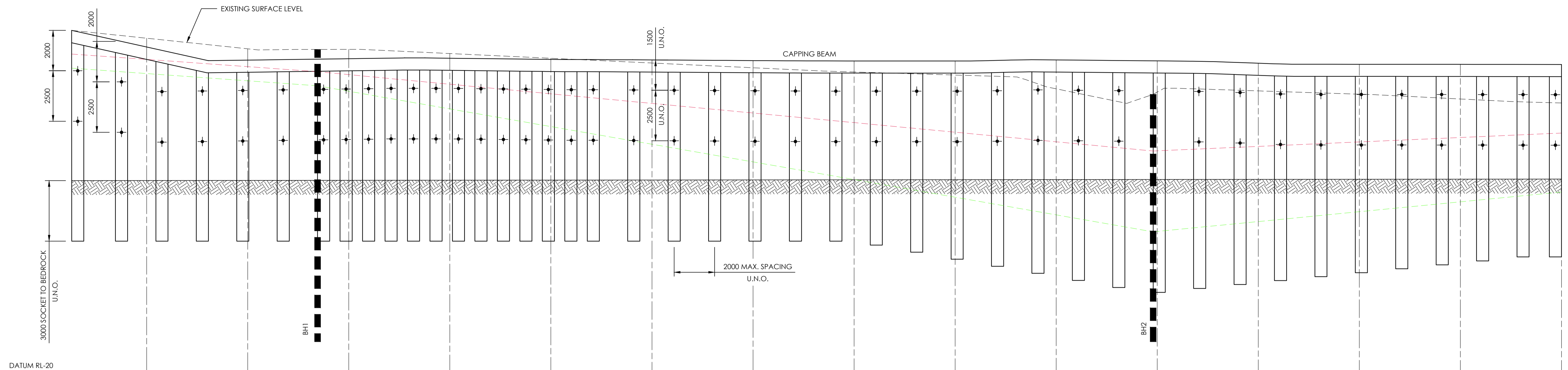

DATUM RL-20	
DETAILED EXCAVATION LEVEL	8.656      8.619      8.601      8.584      8.567      8.549      8.548      8.566      8.584      8.584      8.557      8.531      8.555      8.893      8.631
TOP OF RETAINING WALL	15.179      14.531      14.601      14.625      14.567      14.539      14.507      14.49      14.487      14.54      14.493      14.378      14.325      14.322
HEIGHT OF RETAINING WALL	6.193      5.562      5.650      5.691      5.650      5.640      5.610      5.574      5.553      5.606      5.586      5.498      5.420      5.379
EXISTING SURFACE LEVEL	15.615      15.091      15.063      14.857      14.622      14.387      14.153      13.944      13.792      13.110      12.949      13.008      12.845      12.607      12.453
CHAINAGE	110.000      115.000      120.000      125.000      130.000      135.000      140.000      145.000      150.000      155.000      160.000      165.000      170.000      175.000      180.000

**SHORING WALL RW No.01 ELEVATION - E03**



SCALE 1:100 AT A1

**NOTE**  
 AN ALLOWANCE OF 350mm FROM CIVIL 'BOTTOM OF RETAINING WALL' LEVELS HAS BEEN ALLOWED FOR IN THE CALCULATION OF BULK EXCAVATION LEVELS. CIVIL ENGINEER TO CONFIRM.

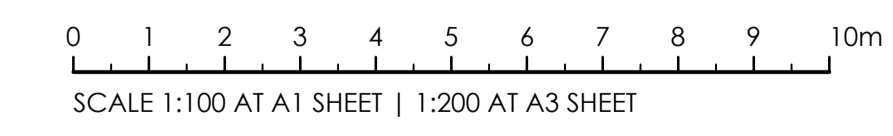
**NOTE**  
 WORKS WITHIN THE ROAD RESERVE ARE SHOWN FOR ASSESSMENT PURPOSES ONLY AND NOT FOR APPROVAL.



ISSUED FOR CLIENT REVIEW 18.03.24      B      S.S. ISSUED FOR CLIENT REVIEW 07.02.24      A      S.S. AMENDMENTS      DATE      ISSUE      BY	NORTH POINT U.N.O.	ARCHITECT	CLIENT <b>AT&amp;L AND ASSOCIATES</b>	PROJECT <b>TRANSPORT DEPOT</b> 7A-11 RACECOURSE RD, 5-9 FAUNCE ST & YOUNG ST, WEST GOSFORD	<b>TRIAxIAL CONSULTING</b> 1300 874 294   TRIAXIAL.AU SUITE 12, LEVEL 14, 327 PITT STREET, SYDNEY NSW 2000 PO BOX A203, SYDNEY SOUTH NSW 1235 <b>COMPLEX PROBLEMS RESOLVED SIMPLY</b> TO BE PRINTED IN COLOUR	DRAWING TITLE <b>SHORING WALL RW No.01 ELEVATION - E03</b> PROJECT No. <b>TX17790.00</b> - <b>S3.03</b> DRAWING No. <b>S3.03</b> ISSUE <b>B</b>
	<b>NOT FOR CONSTRUCTION</b>			DESIGNED RO.O.      DRAWN S.S.      DATE 18.03.24      SIZE A1      CAD REF TX17790.00 - S01		

LEGEND	
	APPROXIMATE LEVEL OF EXTREMELY WEATHERED MATERIAL
	APPROXIMATE LEVEL OF VERY LOW TO LOW STRENGTH BEDROCK
	PERMANENT SHORING ANCHOR

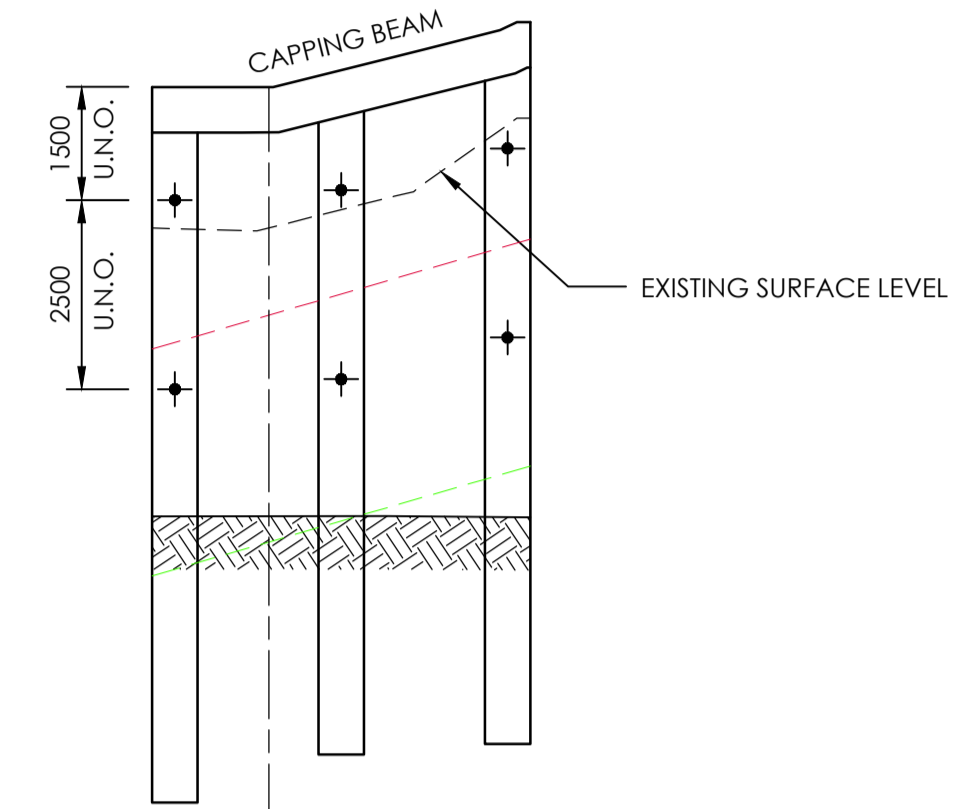

DATUM RL-20

DETAILED EXCAVATION LEVEL	8.631
TOP OF RETAINING WALL	
HEIGHT OF RETAINING WALL	
EXISTING SURFACE LEVEL	12.453
CHAINAGE	180.000

**SHORING WALL RW No.01 ELEVATION - E04**  
SCALE 1:100 AT A1

**NOTE**  
AN ALLOWANCE OF 350mm FROM CIVIL 'BOTTOM OF RETAINING WALL' LEVELS HAS BEEN ALLOWED FOR IN THE CALCULATION OF BULK EXCAVATION LEVELS. CIVIL ENGINEER TO CONFIRM.

**NOTE**  
WORKS WITHIN THE ROAD RESERVE ARE SHOWN FOR ASSESSMENT PURPOSES ONLY AND NOT FOR APPROVAL.

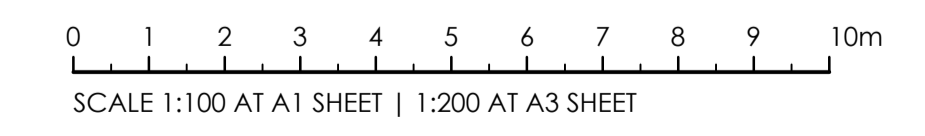

<p>ISSUED FOR CLIENT REVIEW 18.03.24 B S.S.</p> <p>ISSUED FOR CLIENT REVIEW 07.02.24 A S.S.</p> <p>AMENDMENTS DATE ISSUE BY</p>	<p>NORTH POINT U.N.O.</p>	<p>ARCHITECT</p>	<p>CLIENT <b>AT&amp;L AND ASSOCIATES</b></p>	<p>PROJECT <b>TRANSPORT DEPOT</b> 7A-11 RACECOURSE RD, 5-9 FAUNCE ST &amp; YOUNG ST, WEST GOSFORD</p>	 <p><b>TRIAxIAL CONSULTING</b> 1300 874 294   TRIAXIAL.AU SUITE 12, LEVEL 14, 327 PITT STREET, SYDNEY NSW 2000 PO BOX A203, SYDNEY SOUTH NSW 1235</p>	<p>DRAWING TITLE <b>SHORING WALL RW No.01 ELEVATION - E04</b></p>

LEGEND	
	APPROXIMATE LEVEL OF EXTREMELY WEATHERED MATERIAL
	APPROXIMATE LEVEL OF VERY LOW TO LOW STRENGTH BEDROCK
	PERMANENT SHORING ANCHOR

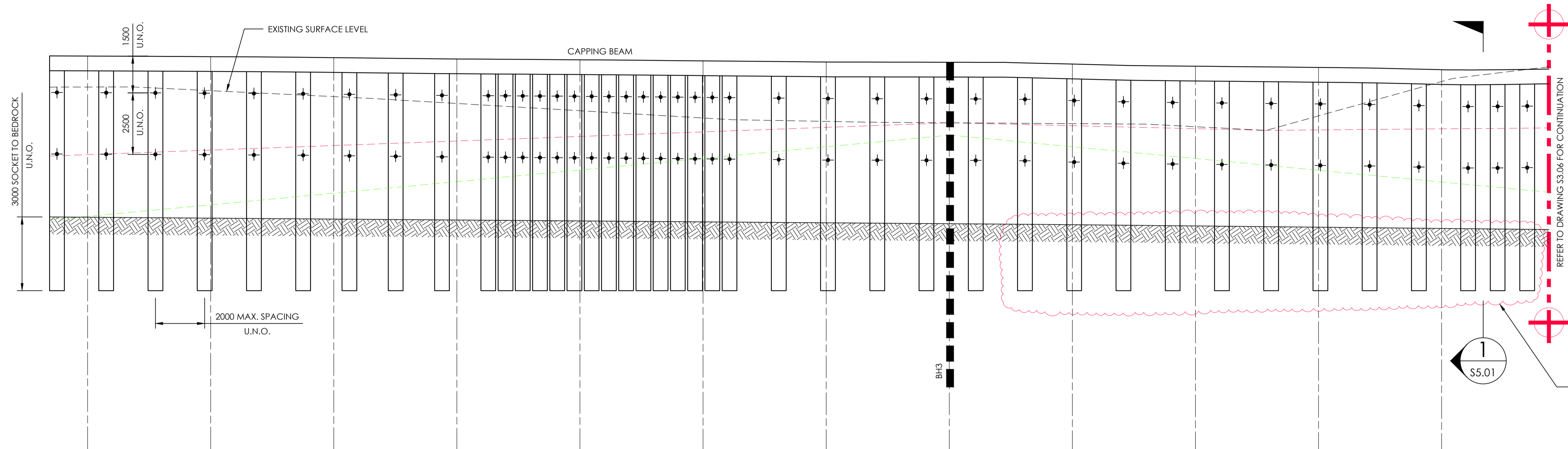

ADDITIONAL DETAILED EXCAVATION REQUIRED FOR STORMWATER. PILE EMBEDMENT REQUIRES FURTHER DEVELOPMENT.

DATUM RL-20	185.000	190.000	195.000	200.000	205.000	210.000	215.000	220.000	225.000	230.000	235.000	240.000
DETAILED EXCAVATION LEVEL	8.617	8.579	8.541	8.233	8.465	8.428	8.390	8.352	8.312	8.261	8.211	8.160
TOP OF RETAINING WALL	15.165	15.141	15.101	15.048	15.014	14.971	14.925	14.913	14.839	14.753	14.703	14.612
HEIGHT OF RETAINING WALL	6.198	6.212	6.210	6.195	6.199	6.193	6.185	6.211	6.177	6.142	6.143	6.102
EXISTING SURFACE LEVEL	13.907	13.759	13.518	13.239	12.944	12.649	12.510	12.453	12.419	12.294	12.736	14.131
CHAINAGE	185.000	190.000	195.000	200.000	205.000	210.000	215.000	220.000	225.000	230.000	235.000	240.000

### SHORING WALL RW No.01 ELEVATION - E05 PART 1

SCALE 1:100 AT A1

**NOTE**  
AN ALLOWANCE OF 350mm FROM CIVIL 'BOTTOM OF RETAINING WALL' LEVELS HAS BEEN ALLOWED FOR IN THE CALCULATION OF BULK EXCAVATION LEVELS. CIVIL ENGINEER TO CONFIRM.

**NOTE**  
WORKS WITHIN THE ROAD RESERVE ARE SHOWN FOR ASSESSMENT PURPOSES ONLY AND NOT FOR APPROVAL.

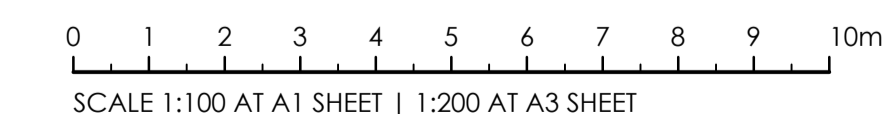

ISSUED FOR CLIENT REVIEW ISSUED FOR CLIENT REVIEW AMENDMENTS	18.03.24    B    S.S. 07.02.24    A    S.S. DATE    ISSUE    BY	NORTH POINT U.N.O. ARCHITECT	CLIENT <b>AT&amp;L AND ASSOCIATES</b>	PROJECT <b>TRANSPORT DEPOT</b> 7A-11 RACECOURSE RD, 5-9 FAUNCE ST & YOUNG ST, WEST GOSFORD	<b>TRIAxIAL CONSULTING</b> 1300 874 294   TRIAXIAL.AU SUITE 12, LEVEL 14, 327 PITT STREET, SYDNEY NSW 2000 PO BOX A203, SYDNEY SOUTH NSW 1235	DRAWING TITLE <b>SHORING WALL RW No.01 ELEVATION - E05 PART 1</b>
	<b>NOT FOR CONSTRUCTION</b>					

LEGEND	
	APPROXIMATE LEVEL OF EXTREMELY WEATHERED MATERIAL
	APPROXIMATE LEVEL OF VERY LOW TO LOW STRENGTH BEDROCK
	PERMANENT SHORING ANCHOR

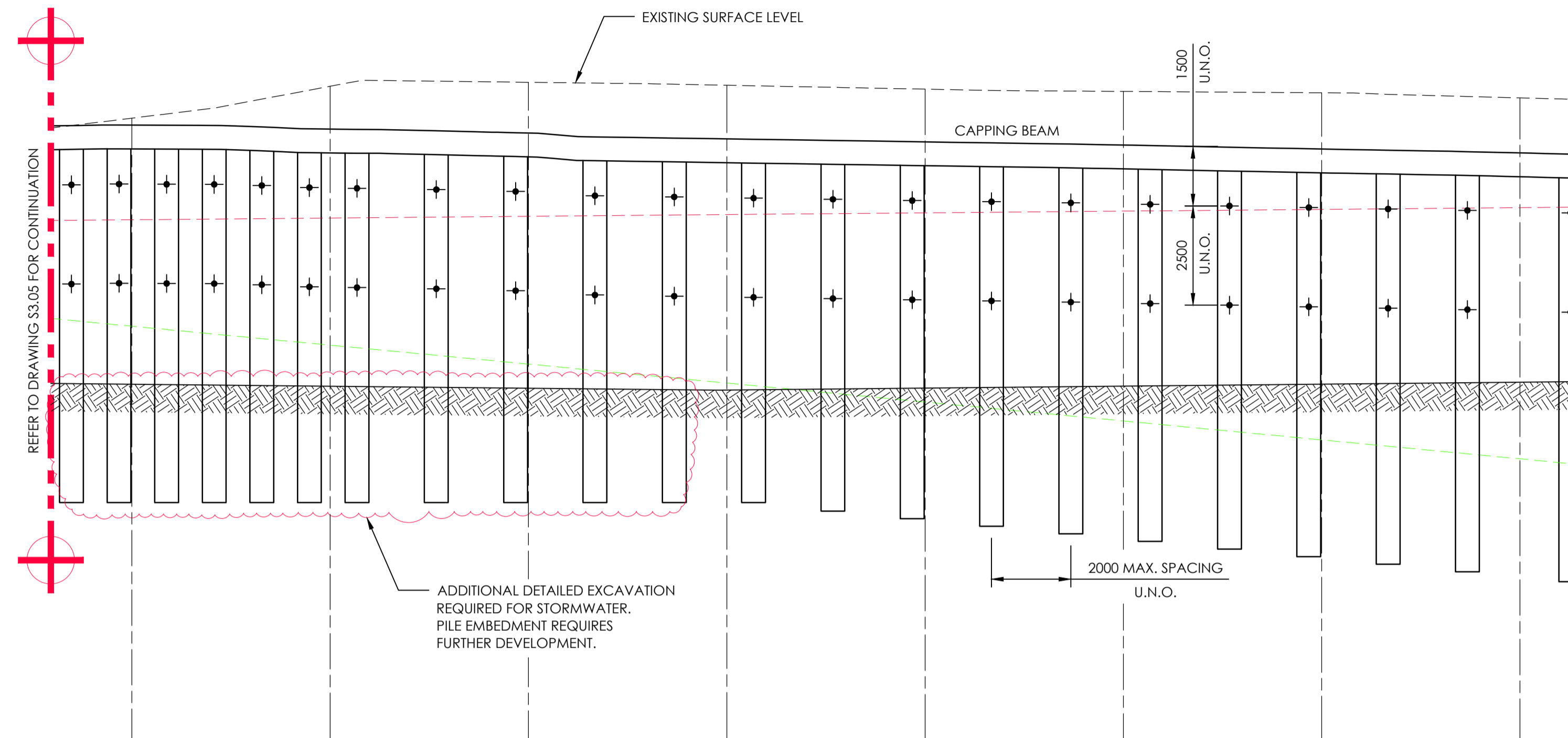

DATUM RL-20	8.109	8.058	8.007	7.960	8.010	8.060	8.110	8.160
DETAILED EXCAVATION LEVEL	8.109	8.058	8.007	7.960	8.010	8.060	8.110	8.160
TOP OF RETAINING WALL	14.635	14.534	14.437	14.289	14.214	14.133	14.033	13.935
HEIGHT OF RETAINING WALL	6.177	6.127	6.080	5.978	5.853	5.723	5.573	5.425
EXISTING SURFACE LEVEL	14.811	15.615	15.715	15.640	15.542	15.484	15.450	15.322
CHAINAGE	245.000	250.000	255.000	260.000	265.000	270.000	275.000	280.000



**SHORING WALL RW No.01 ELEVATION - E05 PART 2**  
SCALE 1:100 AT A1

**NOTE**  
AN ALLOWANCE OF 350mm FROM CIVIL 'BOTTOM OF RETAINING WALL' LEVELS HAS BEEN ALLOWED FOR IN THE CALCULATION OF BULK EXCAVATION LEVELS. CIVIL ENGINEER TO CONFIRM.

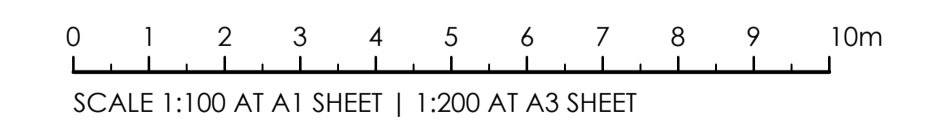
**NOTE**  
WORKS WITHIN THE ROAD RESERVE ARE SHOWN FOR ASSESSMENT PURPOSES ONLY AND NOT FOR APPROVAL.



ISSUED FOR CLIENT REVIEW 18.03.24 B S.S. ISSUED FOR CLIENT REVIEW 07.02.24 A S.S. AMENDMENTS DATE ISSUE BY	NORTH POINT U.N.O.	ARCHITECT	CLIENT <b>AT&amp;L AND ASSOCIATES</b>	PROJECT <b>TRANSPORT DEPOT</b> 7A-11 RACECOURSE RD, 5-9 FAUNCE ST & YOUNG ST, WEST GOSFORD	<b>TRIAxIAL CONSULTING</b> 1300 874 294   TRIAXIAL.AU SUITE 12, LEVEL 14, 327 PITT STREET, SYDNEY NSW 2000 PO BOX A203, SYDNEY SOUTH NSW 1235 <b>COMPLEX PROBLEMS RESOLVED SIMPLY</b> TO BE PRINTED IN COLOUR	DRAWING TITLE <b>SHORING WALL RW No.01 ELEVATION - E05 PART 2</b> PROJECT No. <b>TX17790.00 - S3.06</b> DRAWING No. <b>B</b>
	<b>NOT FOR CONSTRUCTION</b>			DESIGNED RO.O.    DRAWN S.S.    DATE 18.03.24    SIZE A1    CAD REF TX17790.00 - S01		

LEGEND	
	APPROXIMATE LEVEL OF EXTREMELY WEATHERED MATERIAL
	APPROXIMATE LEVEL OF VERY LOW TO LOW STRENGTH BEDROCK
	PERMANENT SHORING ANCHOR

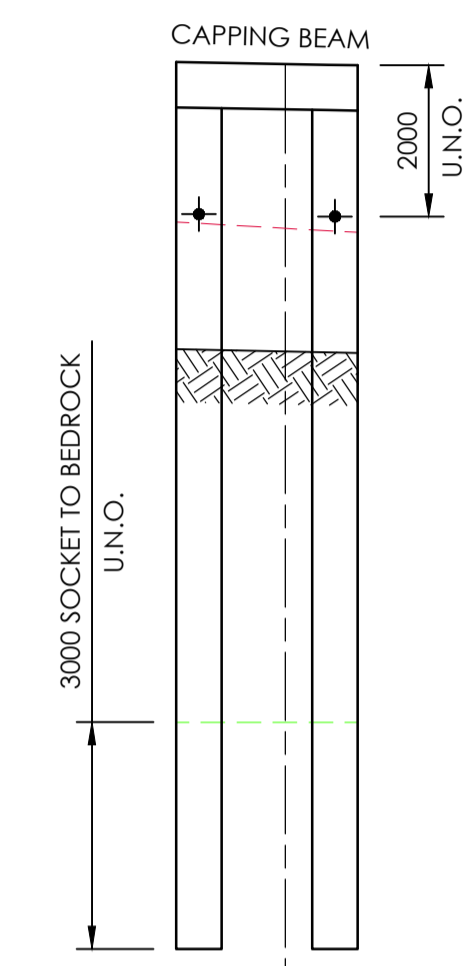
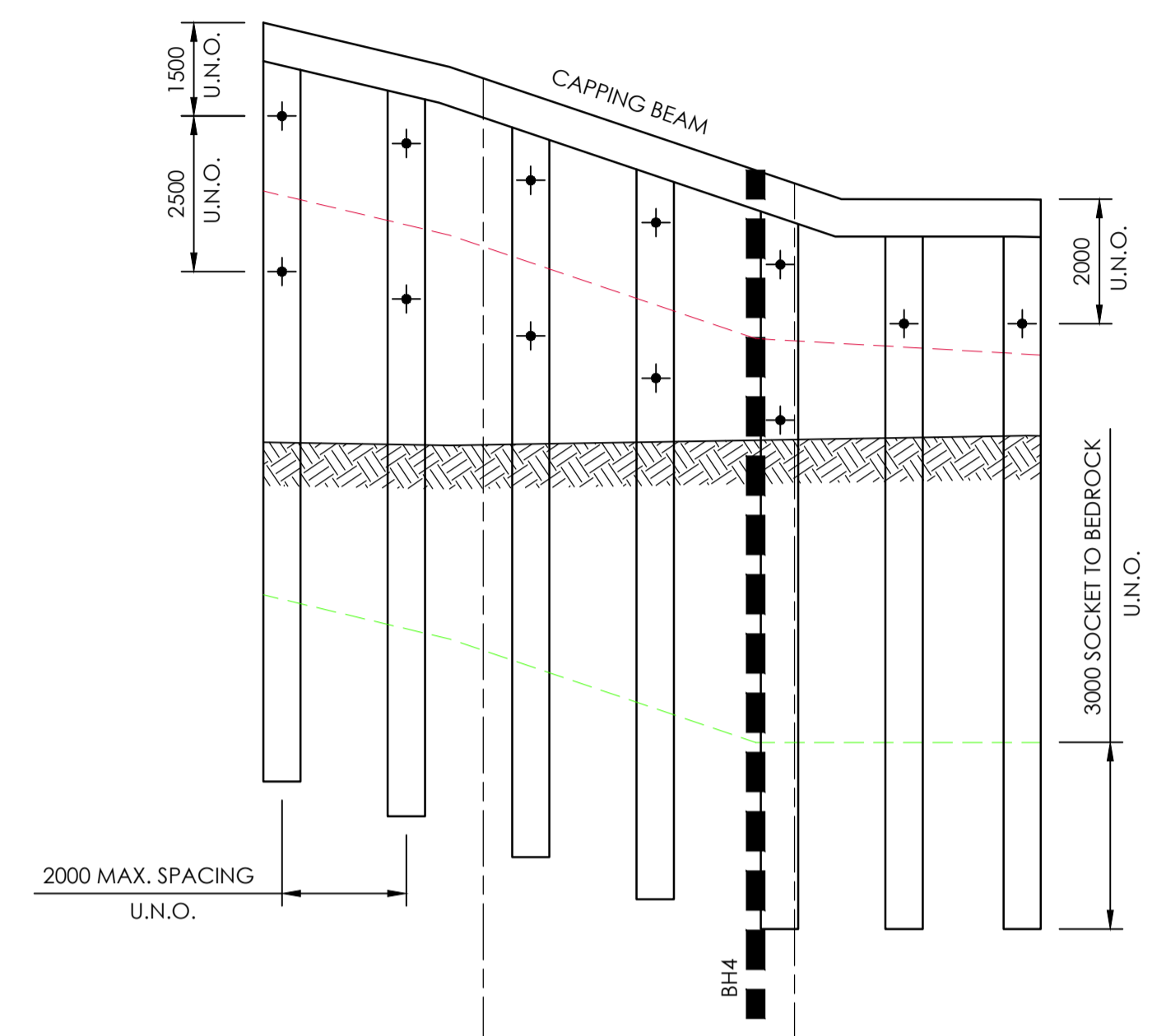
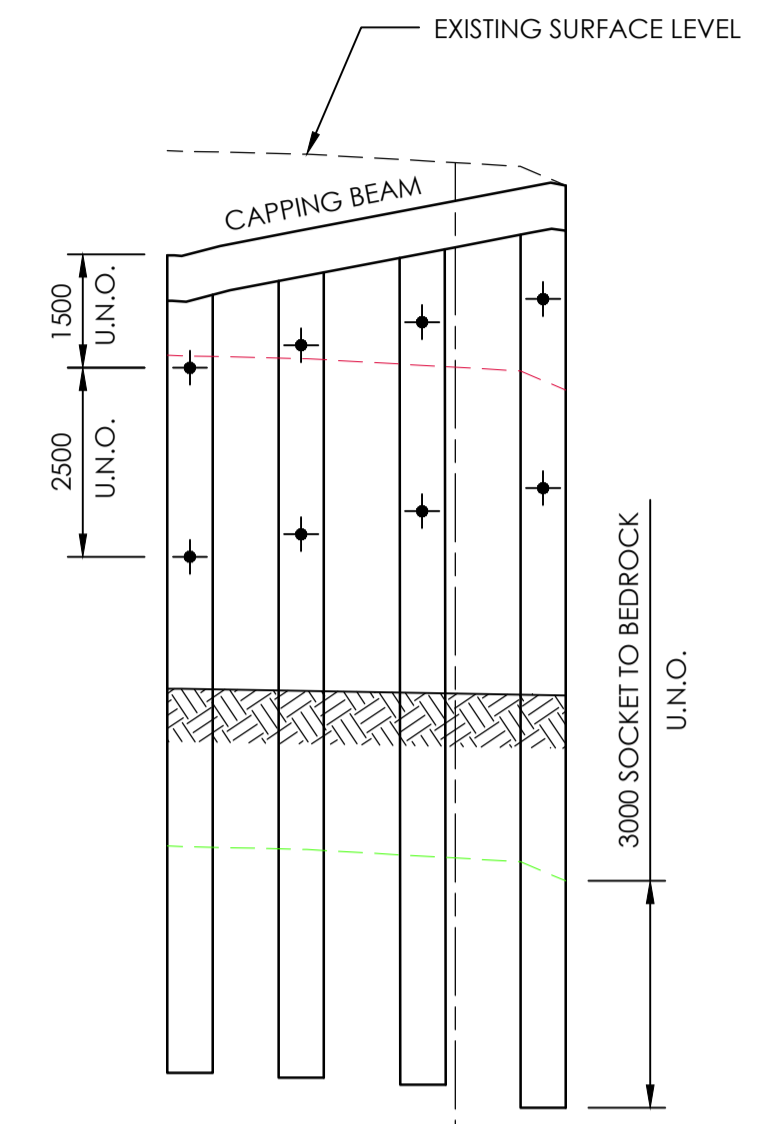

DATUM RL-20	8.112	8.044	8.129	8.166
DETAILED EXCAVATION LEVEL	8.112	8.044	8.129	8.166
TOP OF RETAINING WALL	14.624			
HEIGHT OF RETAINING WALL	6.163	5.633	3.861	3.450
EXISTING SURFACE LEVEL	15.131	13.934	12.246	11.966
CHAINAGE	285.000	290.000	295.000	300.000

SHORING WALL RW No.01 ELEVATION - E06  
SCALE 1:100 AT A1

SHORING WALL RW No.01 ELEVATION - E07  
SCALE 1:100 AT A1



SHORING WALL RW No.01 ELEVATION - E08  
SCALE 1:100 AT A1

**NOTE**  
AN ALLOWANCE OF 350mm FROM CIVIL 'BOTTOM OF RETAINING WALL' LEVELS HAS BEEN ALLOWED FOR IN THE CALCULATION OF BULK EXCAVATION LEVELS. CIVIL ENGINEER TO CONFIRM.

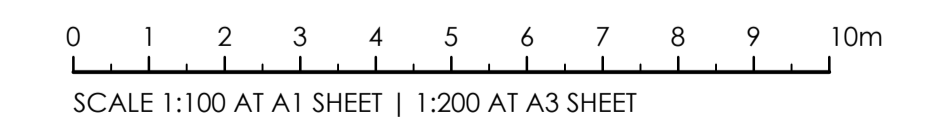
**NOTE**  
WORKS WITHIN THE ROAD RESERVE ARE SHOWN FOR ASSESSMENT PURPOSES ONLY AND NOT FOR APPROVAL.



ISSUED FOR CLIENT REVIEW 18.03.24 B S.S. ISSUED FOR CLIENT REVIEW 07.02.24 A S.S. AMENDMENTS DATE ISSUE BY	NORTH POINT U.N.O.	ARCHITECT	CLIENT <b>AT&amp;L AND ASSOCIATES</b>	PROJECT <b>TRANSPORT DEPOT</b> 7A-11 RACECOURSE RD, 5-9 FAUNCE ST & YOUNG ST, WEST GOSFORD	 <b>TRIAxIAL CONSULTING</b> 1300 874 294   TRIAXIAL.AU SUITE 12, LEVEL 14, 327 PITT STREET, SYDNEY NSW 2000 PO BOX A203, SYDNEY SOUTH NSW 1235 <b>COMPLEX PROBLEMS RESOLVED SIMPLY</b> TO BE PRINTED IN COLOUR	DRAWING TITLE <b>SHORING WALL RW No.01 ELEVATION - E06, E07 &amp; E08</b>
	<b>NOT FOR CONSTRUCTION</b>			DESIGNED RO.O. DRAWN S.S. DATE 18.03.24 SIZE A1 CAD REF TX17790.00 - S01		PROJECT No. <b>TX17790.00 - S3.07</b> DRAWING No. <b>S3.07</b> ISSUE <b>B</b>

LEGEND	
	APPROXIMATE LEVEL OF EXTREMELY WEATHERED MATERIAL
	APPROXIMATE LEVEL OF VERY LOW TO LOW STRENGTH BEDROCK
	PERMANENT SHORING ANCHOR

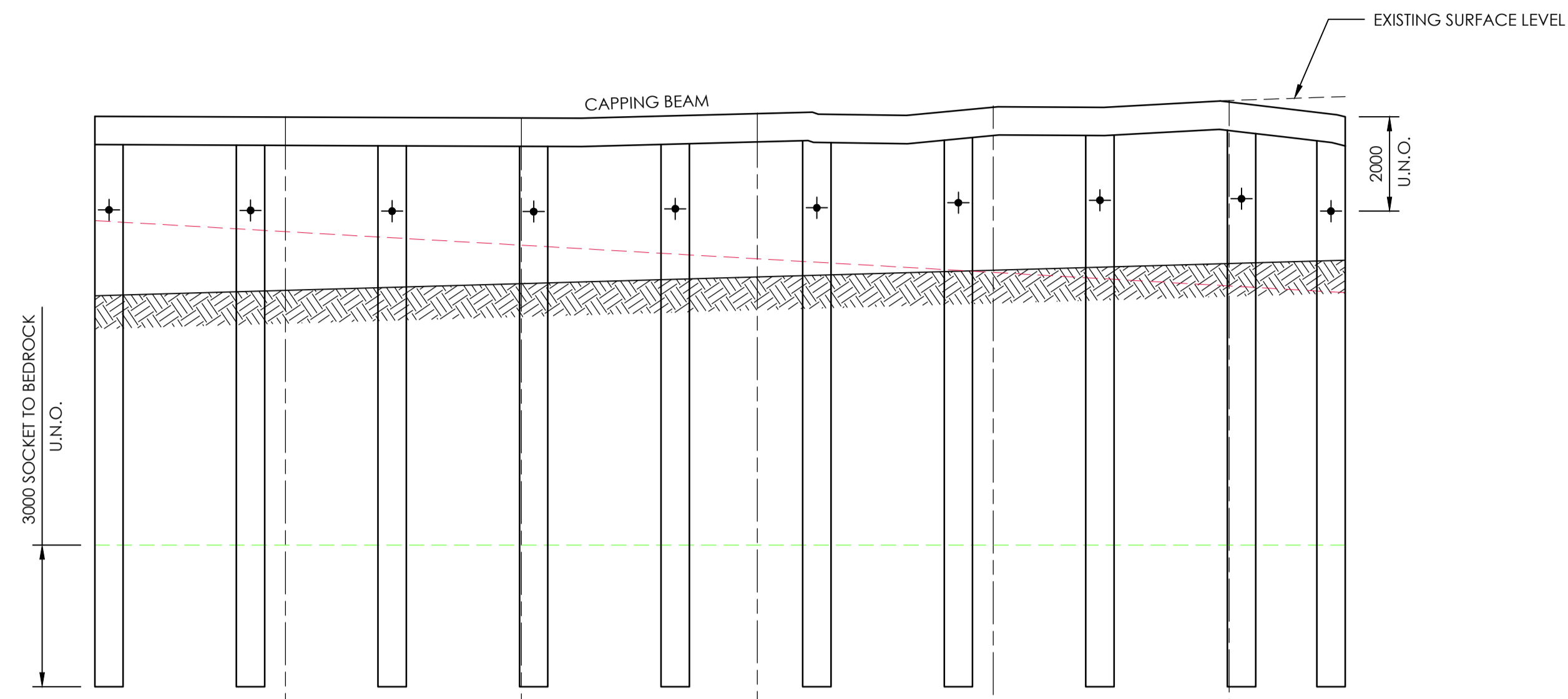

DATUM RL-20						
DETAILED EXCAVATION LEVEL		8.260	8.403	8.545	6.688	8.831
TOP OF RETAINING WALL						12.263
HEIGHT OF RETAINING WALL		3.327	3.165	3.123	3.132	3.072
EXISTING SURFACE LEVEL		11.933	11.914	12.007	12.143	12.283
CHAINAGE		305.000	310.000	315.000	320.000	325.000

### SHORING WALL RW No.01 ELEVATION - E09



SCALE 1:100 AT A1

**NOTE**  
 AN ALLOWANCE OF 350mm FROM CIVIL 'BOTTOM OF RETAINING WALL' LEVELS HAS BEEN ALLOWED FOR IN THE CALCULATION OF BULK EXCAVATION LEVELS. CIVIL ENGINEER TO CONFIRM.

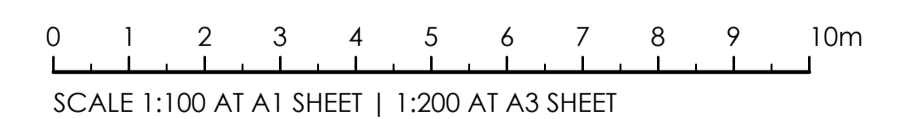
**NOTE**  
 WORKS WITHIN THE ROAD RESERVE ARE SHOWN FOR ASSESSMENT PURPOSES ONLY AND NOT FOR APPROVAL.



ISSUED FOR CLIENT REVIEW ISSUED FOR CLIENT REVIEW AMENDMENTS	18.03.24 B S.S. 07.02.24 A S.S. DATE ISSUE BY	NORTH POINT U.N.O. ARCHITECT	CLIENT <b>AT&amp;L AND ASSOCIATES</b>	PROJECT <b>TRANSPORT DEPOT</b> 7A-11 RACECOURSE RD, 5-9 FAUNCE ST & YOUNG ST, WEST GOSFORD	 <b>TRIAxIAL CONSULTING</b> 1300 874 294   TRIAXIAL.AU SUITE 12, LEVEL 14, 327 PITT STREET, SYDNEY NSW 2000 PO BOX A203, SYDNEY SOUTH NSW 1235	DRAWING TITLE <b>SHORING WALL RW No.01 ELEVATION - E09</b> PROJECT No. <b>TX17790.00 - S3.08</b> DRAWING No. <b>S3.08</b> ISSUE <b>B</b>
	<b>NOT FOR CONSTRUCTION</b>					

LEGEND	
	APPROXIMATE LEVEL OF EXTREMELY WEATHERED MATERIAL
	APPROXIMATE LEVEL OF VERY LOW TO LOW STRENGTH BEDROCK
	PERMANENT SHORING ANCHOR

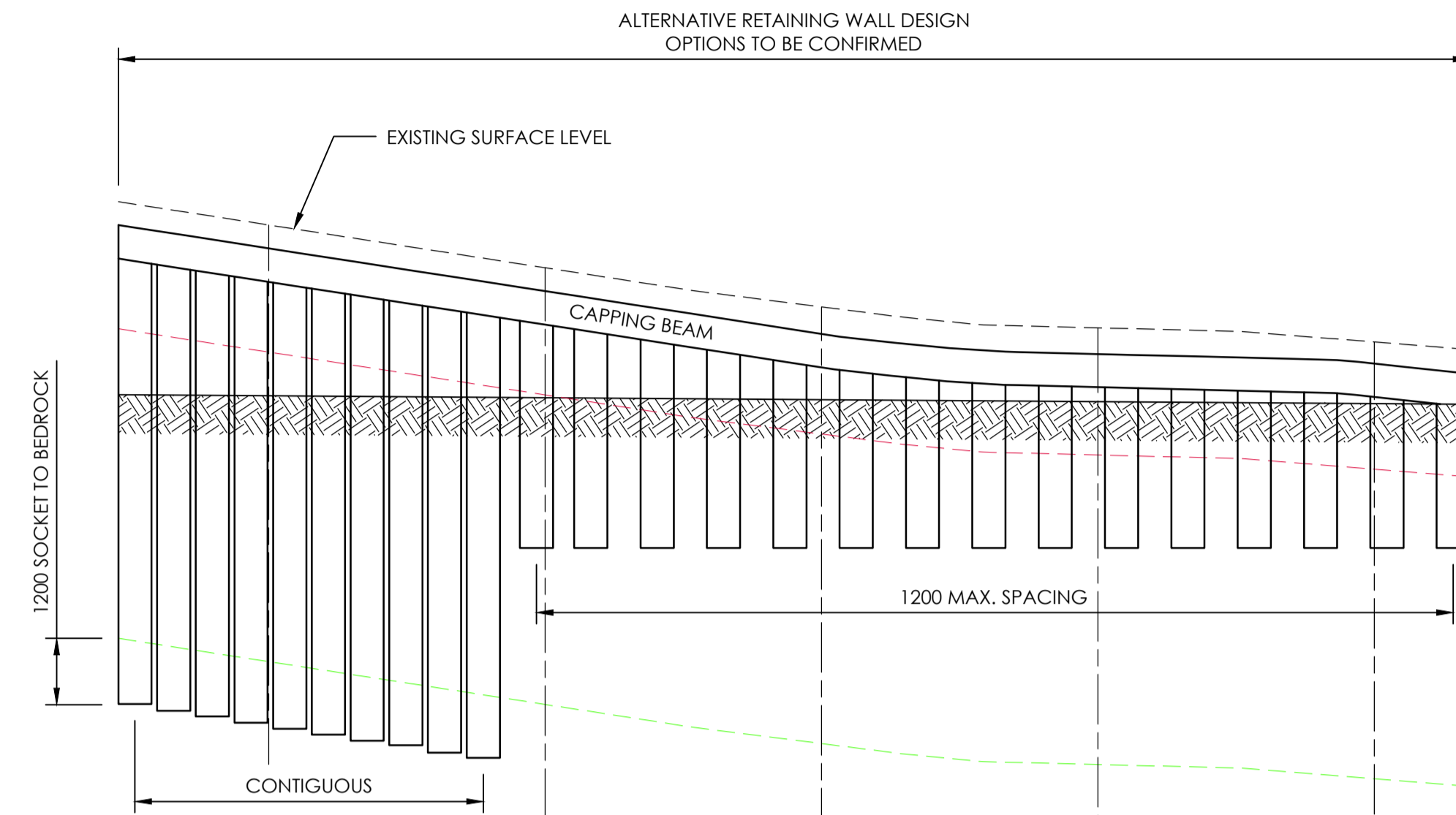



DATUM RL-20						
DETAILED EXCAVATION LEVEL	8.883	8.848	8.813	8.778	8.743	8.731
TOP OF RETAINING WALL	11.551	10.777	10.004	9.639	9.465	
HEIGHT OF RETAINING WALL	2.318	1.579	0.841	0.511	0.372	
EXISTING SURFACE LEVEL	11.974	11.200	10.491	10.113	9.856	9.717
CHAINAGE	330.000	335.000	340.000	345.000	350.000	351.727

**SHORING WALL RW No.01 ELEVATION - E10**  
SCALE 1:100 AT A1

**NOTE**  
AN ALLOWANCE OF 350mm FROM CIVIL 'BOTTOM OF RETAINING WALL' LEVELS HAS BEEN ALLOWED FOR IN THE CALCULATION OF BULK EXCAVATION LEVELS. CIVIL ENGINEER TO CONFIRM.

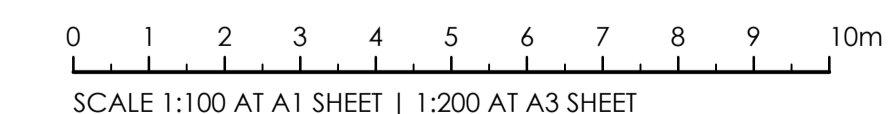
**NOTE**  
WORKS WITHIN THE ROAD RESERVE ARE SHOWN FOR ASSESSMENT PURPOSES ONLY AND NOT FOR APPROVAL.



ISSUED FOR CLIENT REVIEW 18.03.24 B S.S. ISSUED FOR CLIENT REVIEW 07.02.24 A S.S. AMENDMENTS DATE ISSUE BY	NORTH POINT U.N.O.	ARCHITECT	CLIENT <b>AT&amp;L AND ASSOCIATES</b>	PROJECT <b>TRANSPORT DEPOT</b> 7A-11 RACECOURSE RD, 5-9 FAUNCE ST & YOUNG ST, WEST GOSFORD	 <b>TRIAXIAL CONSULTING</b> 1300 874 294   TRIAXIAL.AU SUITE 12, LEVEL 14, 327 PITT STREET, SYDNEY NSW 2000 PO BOX A203, SYDNEY SOUTH NSW 1235 <b>COMPLEX PROBLEMS RESOLVED SIMPLY</b> TO BE PRINTED IN COLOUR	DRAWING TITLE <b>SHORING WALL RW No.01 ELEVATION - E10</b>
	<b>NOT FOR CONSTRUCTION</b>			DESIGNED RO.O. DRAWN S.S. DATE 18.03.24 SIZE A1 CAD REF TX17790.00 - S01		PROJECT No. <b>TX17790.00 - S3.09</b> DRAWING No. ISSUE <b>B</b>

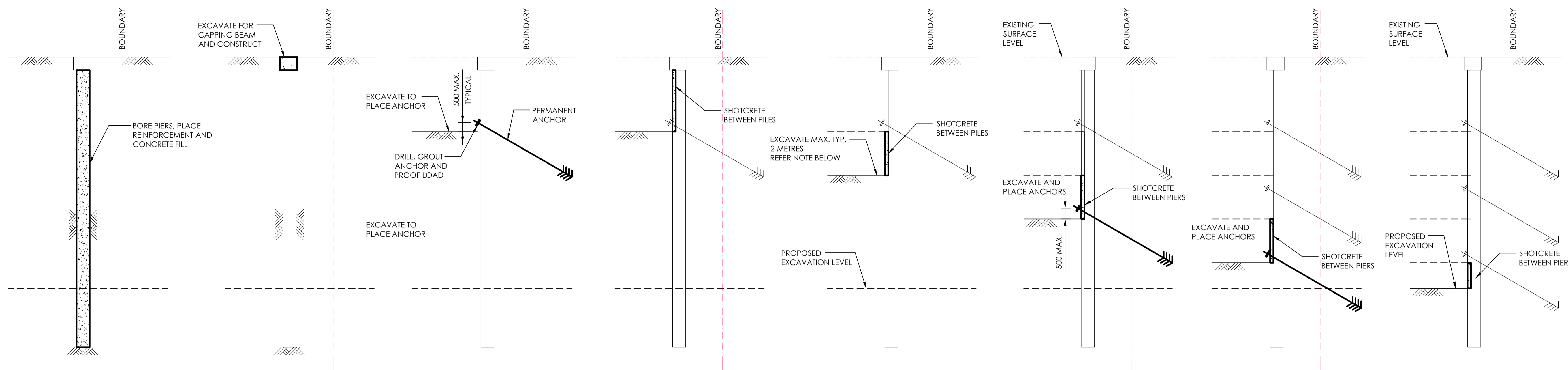

STEPS 5 TO 7 MAY VARY DEPENDING ON PRACTICAL HEIGHTS FOR SHOTCRETING AND ADDITIONAL STAGES MAY BE REQUIRED

**STEP 1**  
EXCAVATE AND FILL PIERS

**STEP 2**  
EXCAVATE AND CAST CAPPING BEAM

**STEP 3**  
EXCAVATE BELOW FIRST ANCHOR AND PLACE ANCHORS

**STEP 4**  
SHOTCRETE BETWEEN PILES

**STEP 5**  
EXCAVATE AND SHOTCRETE BETWEEN PILES

**STEP 6**  
EXCAVATE BELOW SECOND ANCHOR AND PLACE ANCHORS AND SHOTCRETE BETWEEN PILES

**STEP 7**  
EXCAVATE BELOW THIRD ANCHOR AND PLACE ANCHORS AND SHOTCRETE BETWEEN PILES

**STEP 8**  
EXCAVATE TO PROPOSED LEVEL AND SHOTCRETE BETWEEN PILES

**SHORING WALL RW No.01 CONSTRUCTION SEQUENCE**

SCALE 1:100 AT A1

**NOTE**  
GEOTECHNICAL ENGINEER TO ADVISE ON MAXIMUM EXCAVATION HEIGHTS BEFORE SHOTCRETING IS REQUIRED.

**NOTE**  
FOR LOCATIONS WHERE TOP OF THE SHORING WALL IS ABOVE THE TOP OF SURFACE LEVEL, FORMTUBE OR SIMILAR WILL BE REQUIRED TO EXTEND PILES TO THE DESIGN LEVEL.

**NOTE**  
WORKS WITHIN THE ROAD RESERVE ARE SHOWN FOR ASSESSMENT PURPOSES ONLY AND NOT FOR APPROVAL.

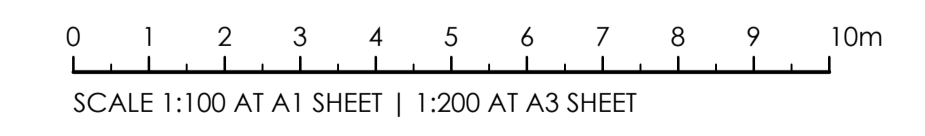

ISSUED FOR CLIENT REVIEW ISSUED FOR CLIENT REVIEW AMENDMENTS	18.03.24    B    S.S. 07.02.24    A    S.S. DATE    ISSUE    BY	NORTH POINT U.N.O. ARCHITECT	CLIENT <b>AT&amp;L AND ASSOCIATES</b>	PROJECT <b>TRANSPORT DEPOT</b> 7A-11 RACECOURSE RD, 5-9 FAUNCE ST & YOUNG ST, WEST GOSFORD	<b>TRIAxIAL CONSULTING</b> 1300 874 294   TRIAXIAL.AU SUITE 12, LEVEL 14, 327 PITT STREET, SYDNEY NSW 2000 PO BOX A203, SYDNEY SOUTH NSW 1235 <b>COMPLEX PROBLEMS RESOLVED SIMPLY</b> <b>TO BE PRINTED IN COLOUR</b>	DRAWING TITLE <b>SHORING WALL RW No.01 CONSTRUCTION SEQUENCE</b>
	<b>NOT FOR CONSTRUCTION</b>	PROJECT No. <b>TX17790.00 - S3.10</b>	DRAWING No. <b>S3.10</b>	ISSUE <b>B</b>		



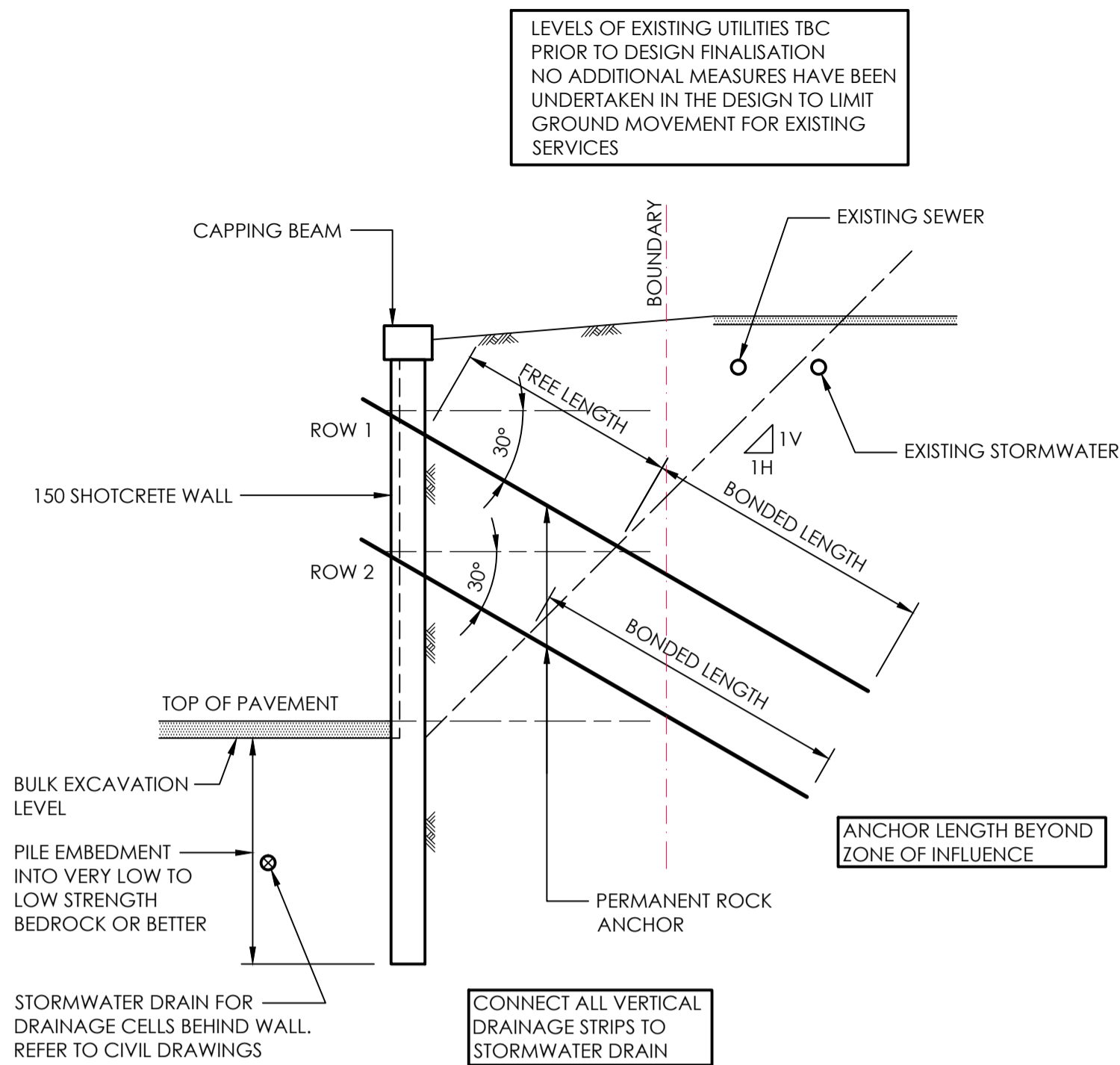

SECTION 1:100 AT A1  
 1 1  
 \$2.03 \$3.05

NOTE:  
 FREE LENGTH IS TO BE GROUTED AFTER ANCHOR IS STRESSED.

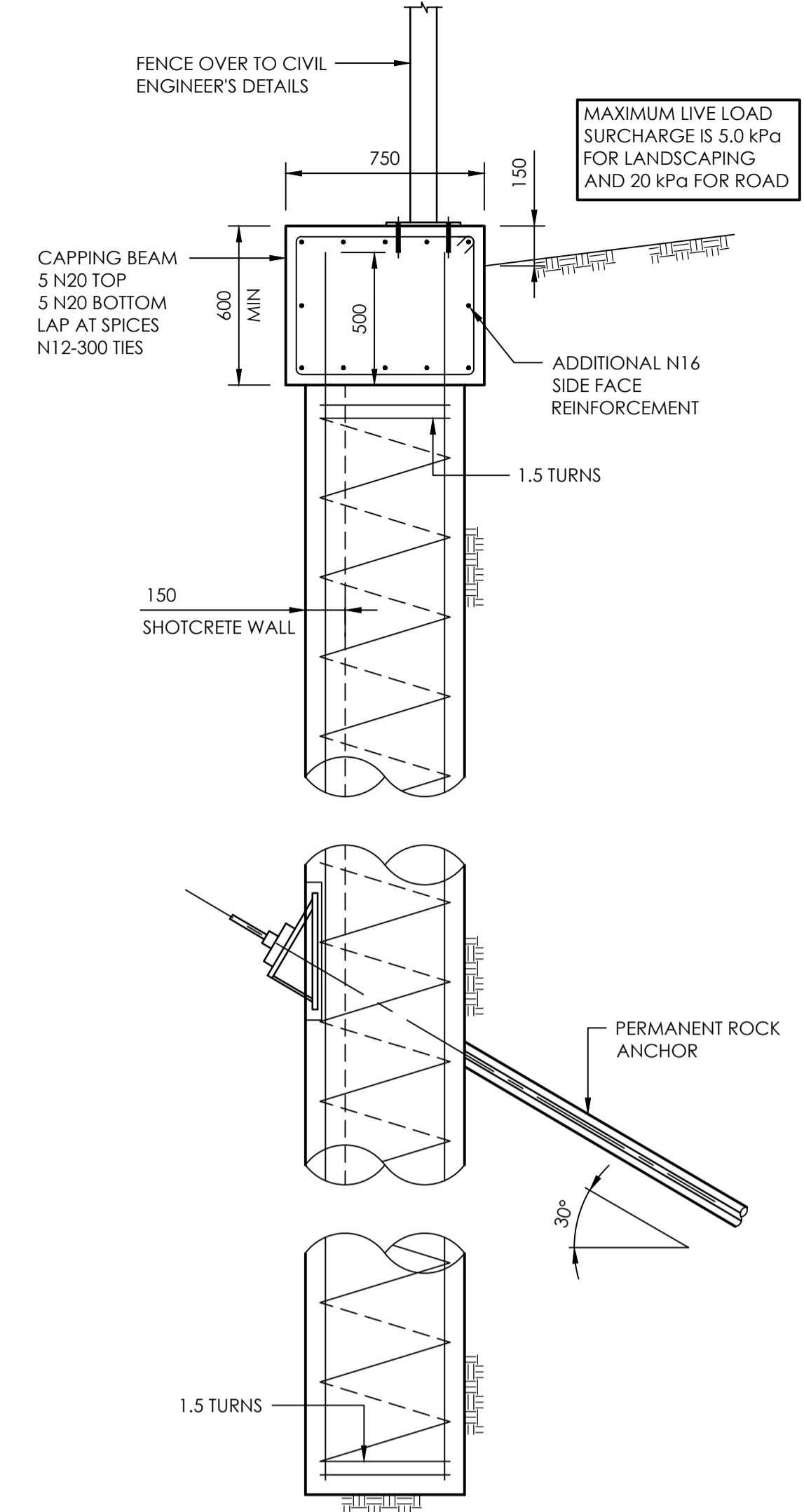

TYPICAL PILE AND CAPPING BEAM DETAIL  
 SCALE 1:20 AT A1

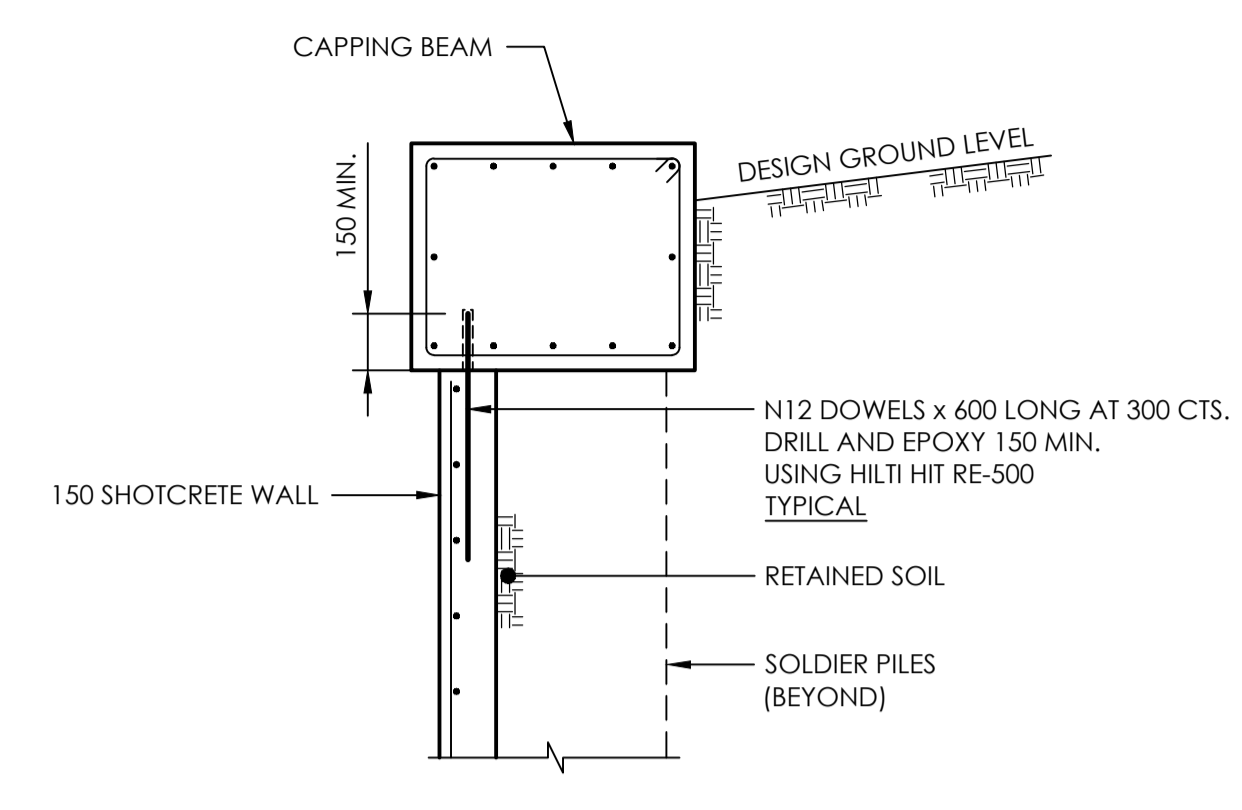

TYPICAL CAPPING BEAM TO SHOTCRETE WALL DETAIL  
 SCALE 1:20 AT A1

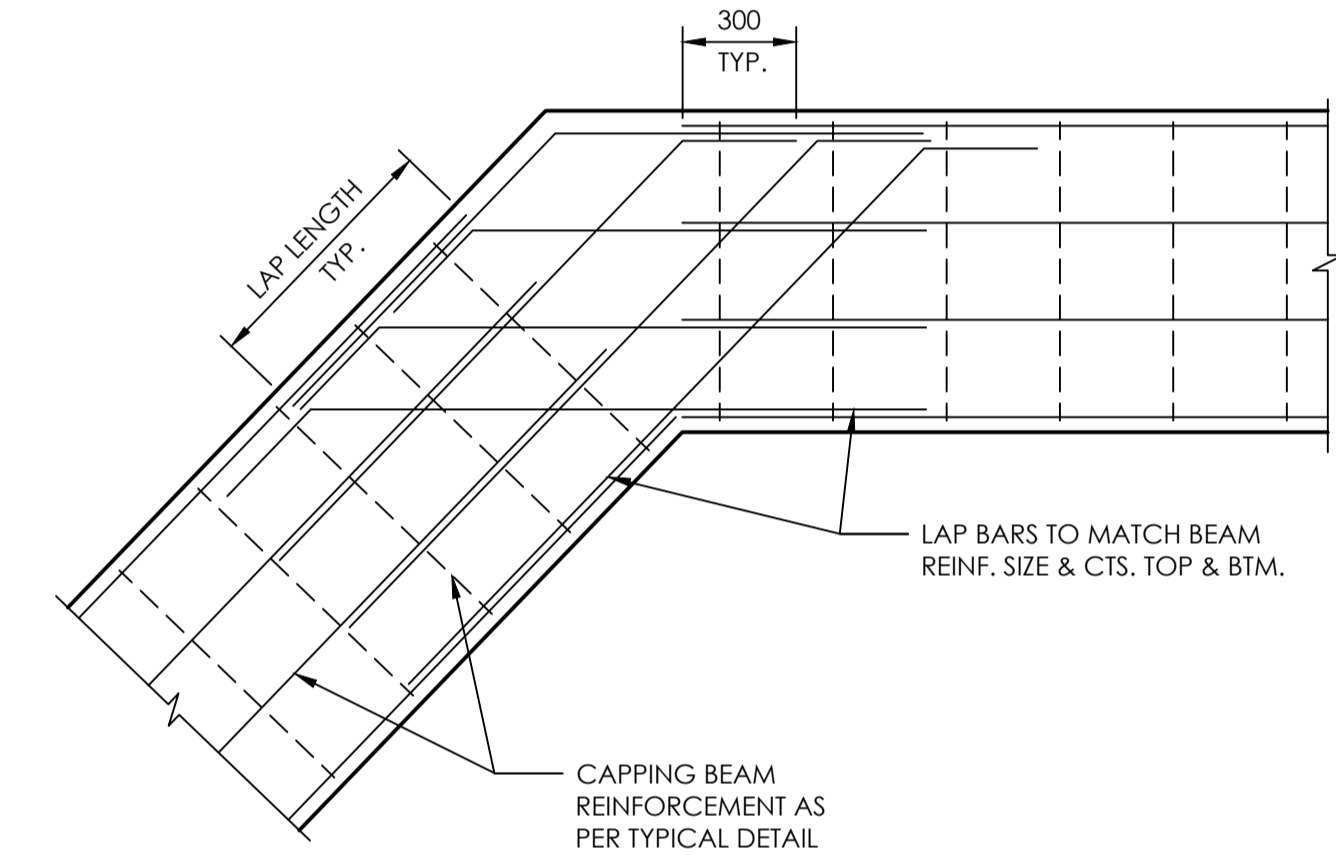

CAPPING BEAM CORNER DETAIL  
 SCALE 1:20 AT A1

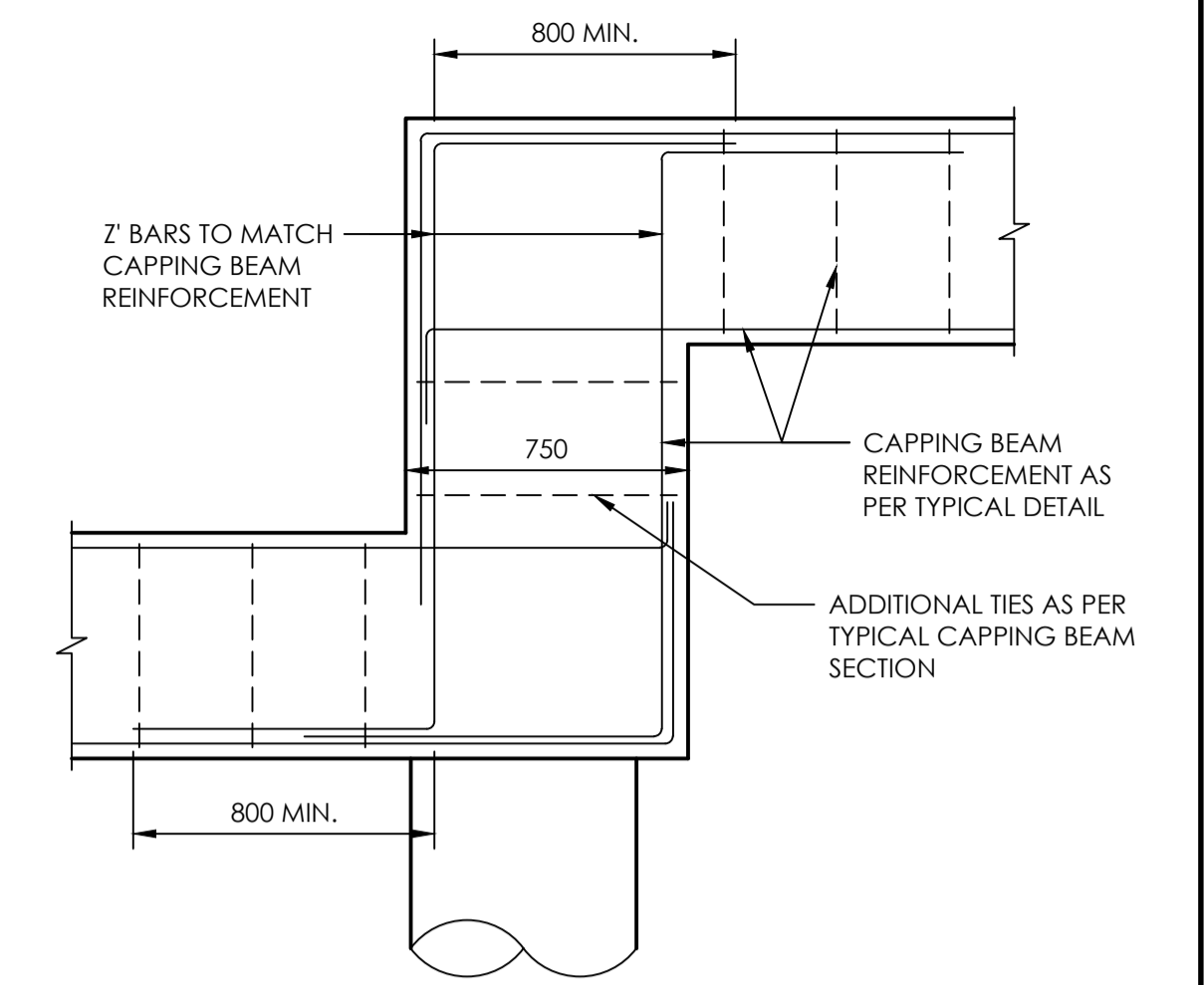

ALTERNATIVE CAPPING BEAM STEP FOR ABRUPT SLOPES DETAIL  
 SCALE 1:20 AT A1

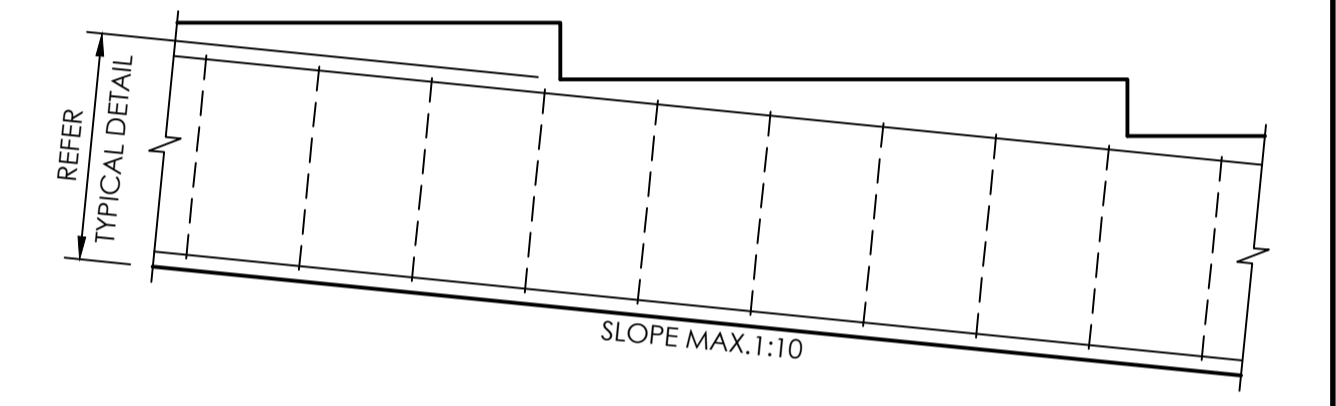

ALTERNATIVE CAPPING BEAM STEP FOR GENTLE SLOPES DETAIL  
 SCALE 1:20 AT A1

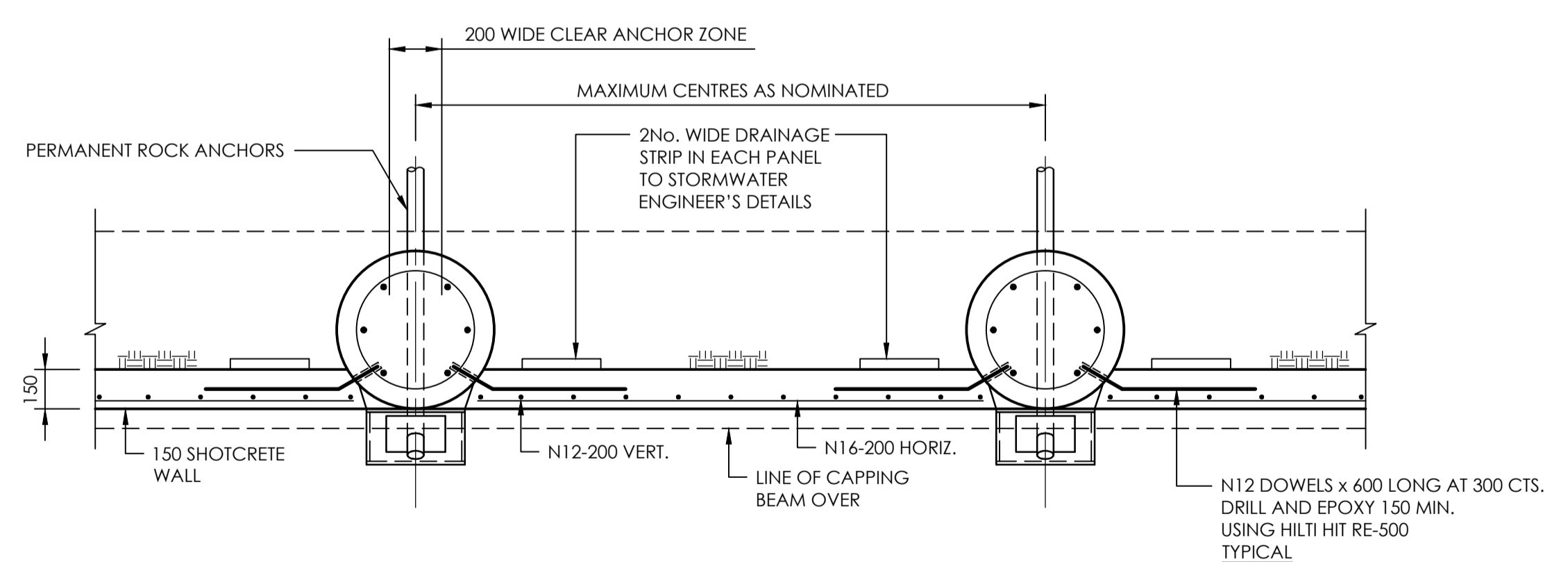

TYPICAL PILE SHOTCRETE WALL PLAN DETAIL  
 SCALE 1:20 AT A1

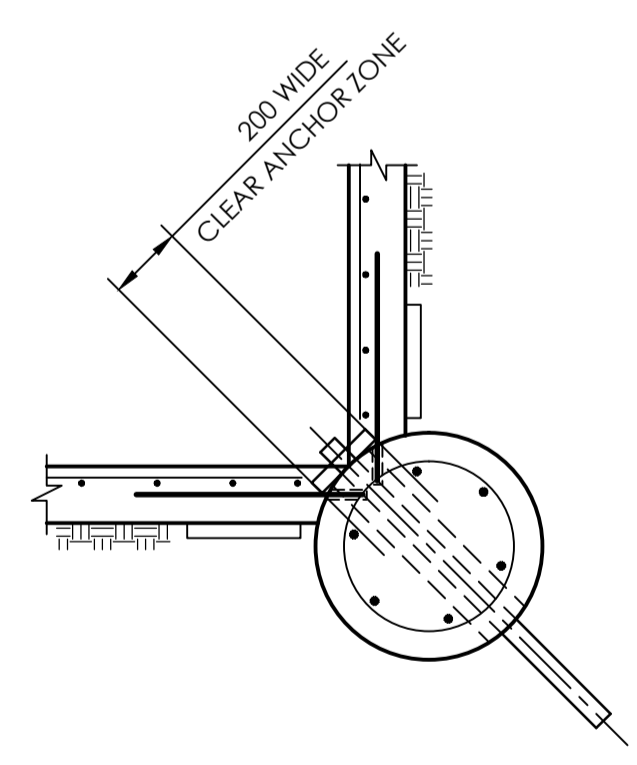

ALTERNATIVE PILE DETAIL AT CORNER JUNCTION  
 SCALE 1:20 AT A1

NOTE  
 WORKS WITHIN THE ROAD RESERVE ARE SHOWN FOR ASSESSMENT PURPOSES ONLY AND NOT FOR APPROVAL.

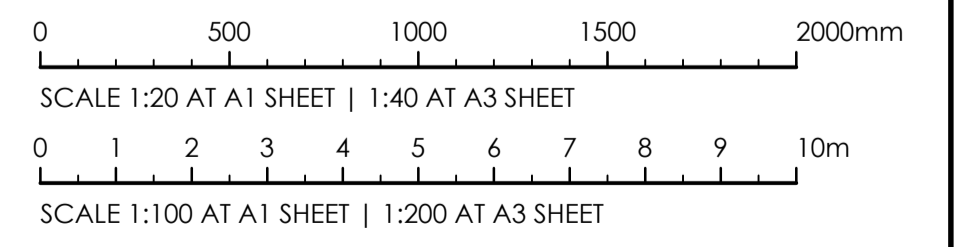

ISSUED FOR CLIENT REVIEW 18.03.24 B S.S.  
 ISSUED FOR CLIENT REVIEW 07.02.24 A S.S.  
 AMENDMENTS DATE ISSUE BY

**NOT FOR CONSTRUCTION**

NORTH POINT U.N.O.  
 ARCHITECT

CLIENT  
**AT&L AND ASSOCIATES**

PROJECT  
**TRANSPORT DEPOT**  
 7A-11 RACECOURSE RD,  
 5-9 FAUNCE ST & YOUNG ST, WEST GOSFORD

DESIGNED RO.O. DRAWN S.S. DATE 18.03.24 SIZE A1 CAD REF TX17790.00 - S01

**TRIAxIAL CONSULTING**  
 COMPLEX PROBLEMS RESOLVED SIMPLY

1300 874 294 | TRIAXIAL.AU  
 SUITE 12, LEVEL 14, 327 PITT STREET, SYDNEY NSW 2000  
 PO BOX A203, SYDNEY SOUTH NSW 1235

TO BE PRINTED IN COLOUR

DRAWING TITLE  
**SHORING WALL DETAILS**

PROJECT No. TX17790.00 - ISSUE S5.01

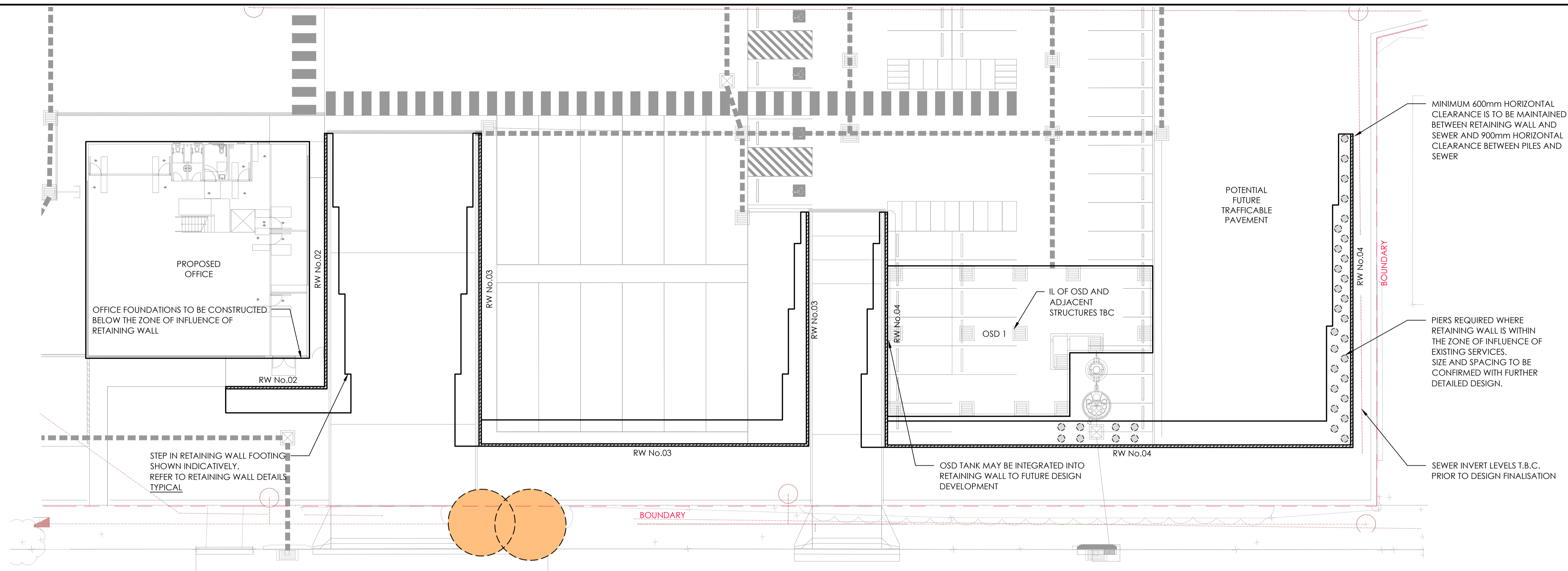

**PART PLAN RETAINING WALL RW No.02, 03 AND 04**  
SCALE 1:200 AT A1

LEGEND	
	STRUCTURAL ROOT ZONE 'SRZ' OF TREES TO REMAIN
	EXISTING IN GROUND SERVICES
	PIERS

**REINFORCED BLOCKWORK SPECIFICATIONS:**

RB1 SPECIFICATION TO BE READ IN CONJUNCTION WITH GENERAL NOTES

RB2 **REINFORCEMENT**  
REINFORCEMENT BLOCKWORK SPECIFICATION U.N.O.  
- VERTICAL BARS: REFER DETAILS  
- HORIZONTAL BARS: REFER DETAILS

RB3 PROVIDE ADDITIONAL REINFORCEMENT AT THE FOLLOWING LOCATIONS:  
- CORNERS  
- INTERSECTIONS  
- ENDS  
- EITHER SIDE OF CONTROL JOINTS

RB4 PROVIDE STARTER BARS TO MATCH VERTICAL BARS AT ALL REINFORCED CORES, EMBED INTO FOOTING WITH LAP & COG AS NOTED:

SIZE	LAP	COG	MIN. EMBED.
N12	600	180	300
N16	750	200	300
N20	950	240	350

RB5 **GROUT**  
ALL CORES FULLY GROUTED

RB6 GROUT SPECIFICATION:  
- 20MPa  
- MAX 10mm AGGREGATE SIZE  
- 120mm SLUMP

RB7 USE CLEANOUT BLOCKS TO BASE COURSE

RB8 EXTERNAL BLOCKWORK & BLOCKWORK BELOW GROUND LEVEL SHALL BE CONSTRUCTED USING MORTAR DAMP-PROOF ADMIXTURE SUCH AS 'CEMENT AID CALBLACK' OR SIMILAR FOR THE FIRST 3 COURSES ABOVE FINISHED FLOOR LEVEL.

RB9 15MPa MINIMUM CAPACITY OF BLOCKS

FOOTING CONCRETE QUALITY					
ELEMENT	AS3600 EXPOSURE CLASS.	AS1379 CONCRETE CLASS.	f <sub>c</sub> (MPa)	CEMENT TYPE	REMARKS
FOOTINGS	A2	N	32	GP	

ALL CONCRETE TO HAVE 20mm MAX. AGG. SIZE WITH 80mm SLUMP U.N.O.  
ADMIXTURES ARE THE RESPONSIBILITY OF SUPPLIER  
f<sub>c</sub> DENOTES CHARACTERISTIC COMPRESSIVE STRENGTH  
REFER TO GENERAL NOTES FOR CONCRETE COVER RELATED TO EXPOSURE CLASSIFICATION

FOOTING NOTES	
1.	FOR ADDITIONAL REINFORCEMENT AND OTHER REQUIREMENTS, REFER TO DETAILS.
2.	ALL FOOTINGS TO BE EMBEDDED 200 MIN. INTO NATURAL GROUND OR CERTIFIED CONTROL FILL.
3.	40mm LAGGING TO ALL NON-VERTICAL PIPES.
4.	DEPTH OF UNCONTROLLED FILL IS NOT TO EXCEED 400mm. IF FILL EXCEEDS 400mm IN DEPTH THEN FOOTING BEAMS ARE TO BE EMBEDDED 200 MIN. INTO NATURAL GROUND (UNLESS PIERS ARE SHOWN).
5.	DURING CONSTRUCTION, WATER RUN-OFF SHALL BE COLLECTED & CHANNLED AWAY FROM THE BUILDING.
6.	WORKS TO BE IN ACCORDANCE WITH AS 2870 & AS 3600.

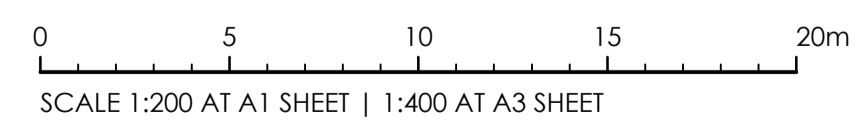

ISSUED FOR CLIENT REVIEW  
AMENDMENTS

DATE	ISSUE	BY
07.02.24	A	S.S.

**NOT FOR CONSTRUCTION**

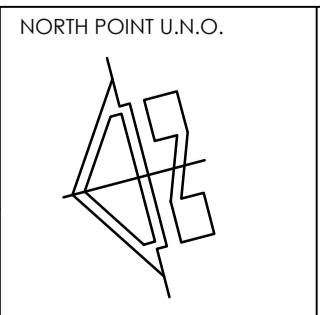

NORTH POINT U.N.O.  
ARCHITECT

CLIENT  
**AT&L AND ASSOCIATES**

PROJECT  
**TRANSPORT DEPOT**  
7A-11 RACECOURSE RD,  
5-9 FAUNCE ST & YOUNG ST, WEST GOSFORD

DESIGNED	DRAWN	DATE	SIZE	CAD REF
RO.O.	S.S.	18.03.24	A1	TX17790.00 - S01



1300 874 294 | TRIAXIAL.AU  
SUITE 12, LEVEL 14, 327 PITT STREET, SYDNEY NSW 2000  
PO BOX A203, SYDNEY SOUTH NSW 1235

TO BE PRINTED IN COLOUR

DRAWING TITLE  
**RETAINING WALL PART PLAN**

PROJECT No. **TX17790.00 - S6.01** DRAWING No. **S6.01** ISSUE **A**

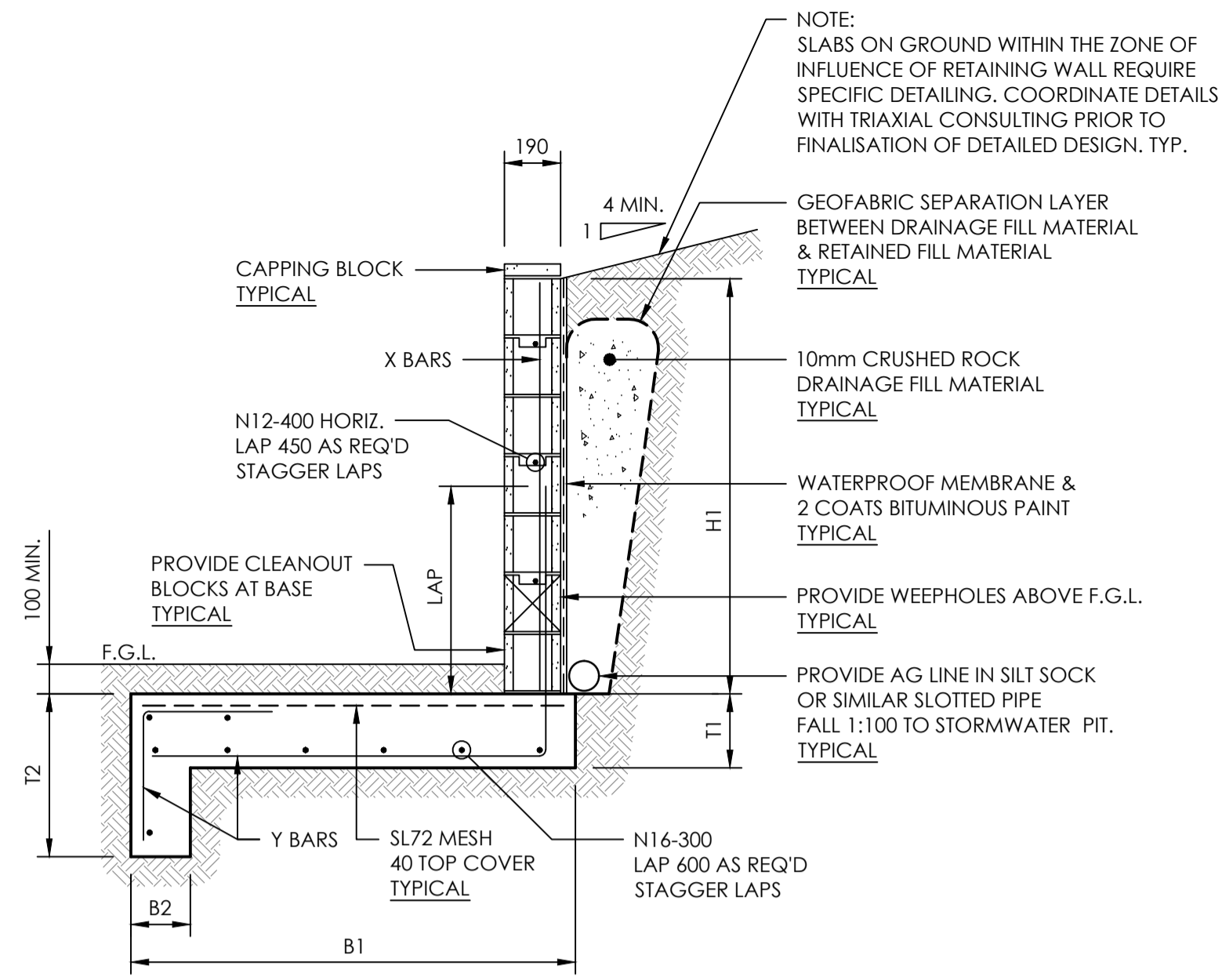

**BLOCKWORK RETAINING WALL TYPE A1**  
HEIGHT UP TO 2000  
SCALE 1:20 AT A1

RETAINING WALL TYPE A1 SPECIFICATIONS						
RETAINED HEIGHT H1	BASE THICKNESS T1	BASE KEY DEPTH T2	BASE WIDTH B1	BASE KEY WIDTH B2	REINFT X BARS	REINFT Y BARS
600	300	600	900	300	N12-400	N12-400
1200	300	800	1200	300	N12-400	N12-400
1600	300	900	1800	300	N16-400	N16-400
2000	300	1200	2200	300	N16-200	N16-200

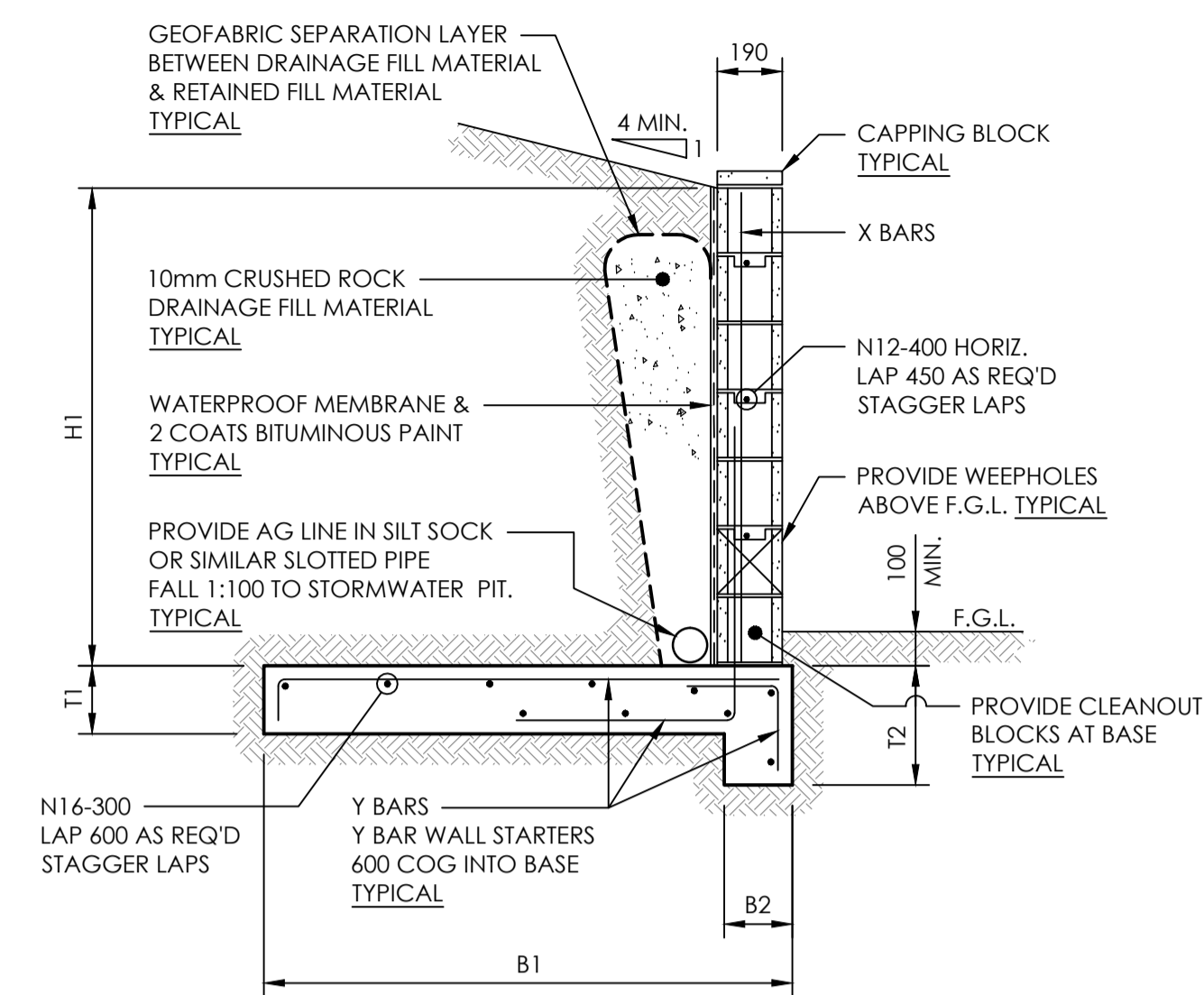

**BLOCKWORK RETAINING WALL TYPE B1**  
HEIGHT UP TO 2000  
SCALE 1:20 AT A1

RETAINING WALL TYPE B1 SPECIFICATIONS						
RETAINED HEIGHT H1	BASE THICKNESS T1	BASE KEY DEPTH T2	BASE WIDTH B1	BASE KEY WIDTH B2	REINFT X BARS	REINFT Y BARS
600	300	600	600	300	N12-400	N12-400
1200	300	800	1200	300	N12-400	N12-400
1600	300	900	1600	300	N16-400	N16-400
2000	300	1200	1800	300	N16-200	N16-200

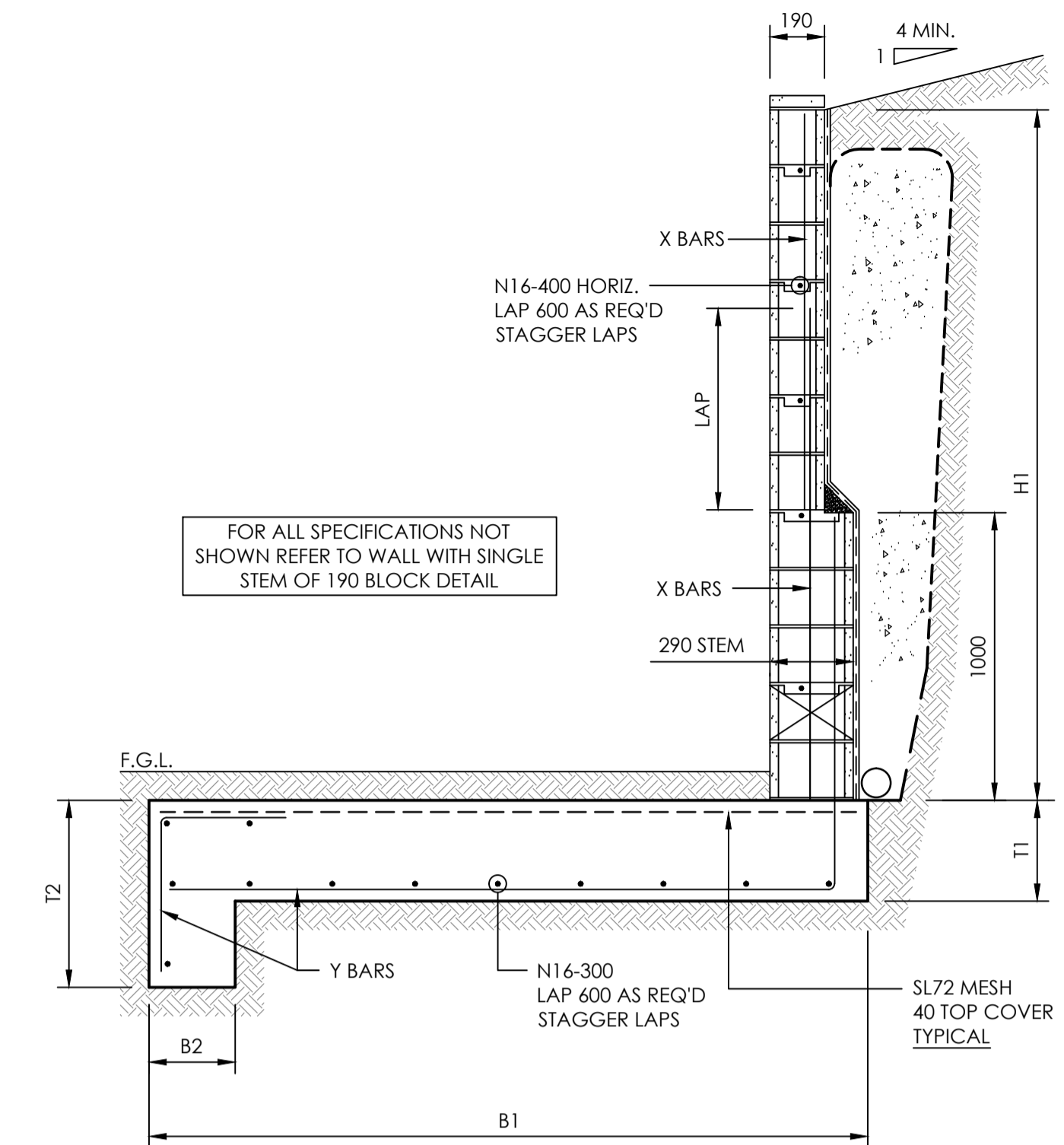

**BLOCKWORK RETAINING WALL TYPE A2**  
2000 TO 3000 HIGH  
SCALE 1:20 AT A1

RETAINING WALL TYPE A2 SPECIFICATIONS						
RETAINED HEIGHT H1	BASE THICKNESS T1	BASE KEY DEPTH T2	BASE WIDTH B1	BASE KEY WIDTH B2	REINFT X BARS	REINFT Y BARS
2600	300	1400	2900	300	N16-200	N16-200
3000	300	1500	3500	300	N20-200	N20-200

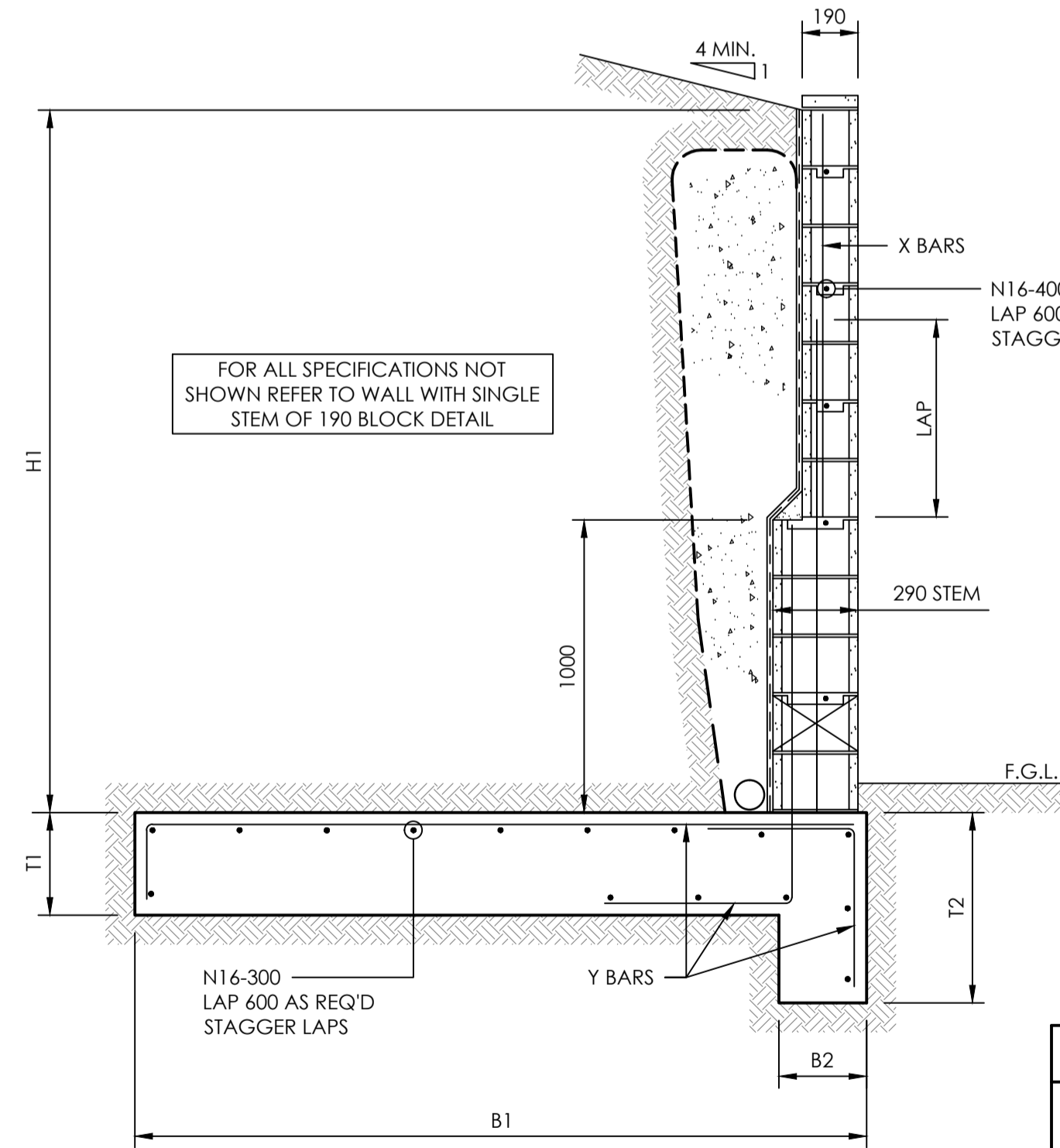

**BLOCKWORK RETAINING WALL TYPE B2**  
2000 TO 3000 HIGH  
SCALE 1:20 AT A1

RETAINING WALL TYPE B2 SPECIFICATIONS						
RETAINED HEIGHT H1	BASE THICKNESS T1	BASE KEY DEPTH T2	BASE WIDTH B1	BASE KEY WIDTH B2	REINFT X BARS	REINFT Y BARS
2600	300	1200	2500	300	N16-200	N16-200
3000	300	1200	3000	300	N20-200	N20-200

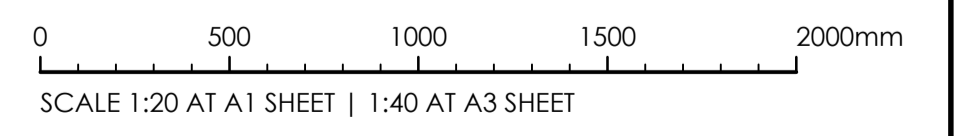

ISSUED FOR CLIENT REVIEW  
AMENDMENTS

07.02.24	A	S.S.
DATE	ISSUE	BY

**NOT FOR CONSTRUCTION**

NORTH POINT U.N.O.  
ARCHITECT

CLIENT  
**AT&L AND ASSOCIATES**

PROJECT  
**TRANSPORT DEPOT**  
7A-11 RACECOURSE RD,  
5-9 FAUNCE ST & YOUNG ST, WEST GOSFORD

DESIGNED RO.O. DRAWN S.S. DATE 18.03.24 SIZE A1 CAD REF TX17790.00 - 501



1300 874 294 | TRIAXIAL.AU  
SUITE 12, LEVEL 14, 327 PITT STREET, SYDNEY NSW 2000  
PO BOX A203, SYDNEY SOUTH NSW 1235

**TO BE PRINTED IN COLOUR**

DRAWING TITLE  
**RETAINING WALL DETAILS SHEET 1**

PROJECT No. **TX17790.00 - S6.02** DRAWING No. **S6.02** ISSUE **A**

**NOTE:**  
RETAINING WALLS TO BE FOUNDED ON CONSISTENT RESIDUAL MATERIAL FOR THE FULL AREA OF FOOTING AND LENGTH OF WALL. SHOULD GEOTECHNICAL CONDITIONS VARY ALONG THE LENGTH OF THE WALL, STRUCTURAL MODIFICATIONS OF THE DESIGN MAY BE REQUIRED. CONTACT TRIAXIAL CONSULTING PRIOR TO CONSTRUCTION OF WALL.

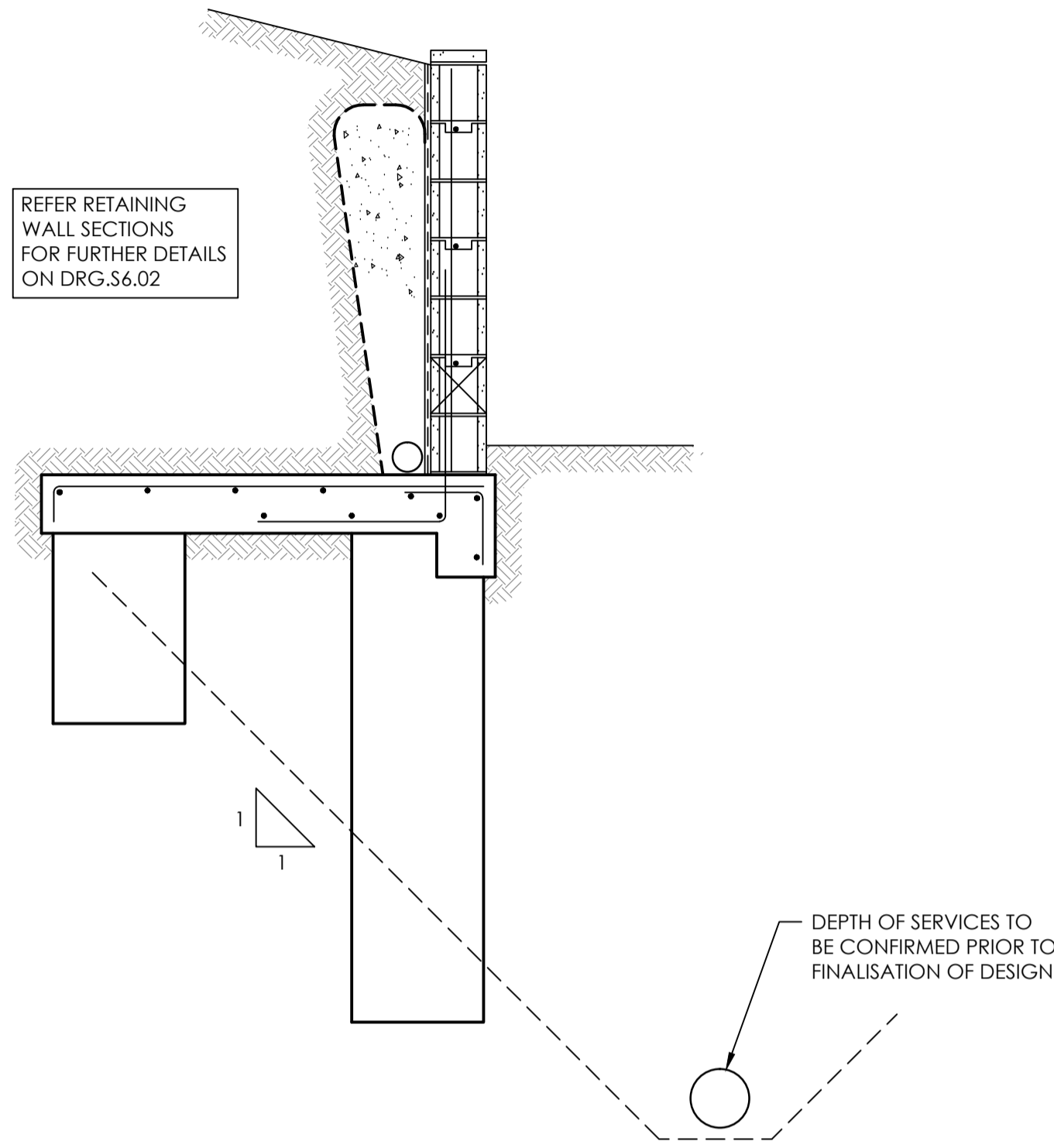

**BLOCKWORK RETAINING WALL TYPE B1  
WITHIN ZONE OF INFLUENCE OF SERVICES**  
SCALE 1:20 AT A1

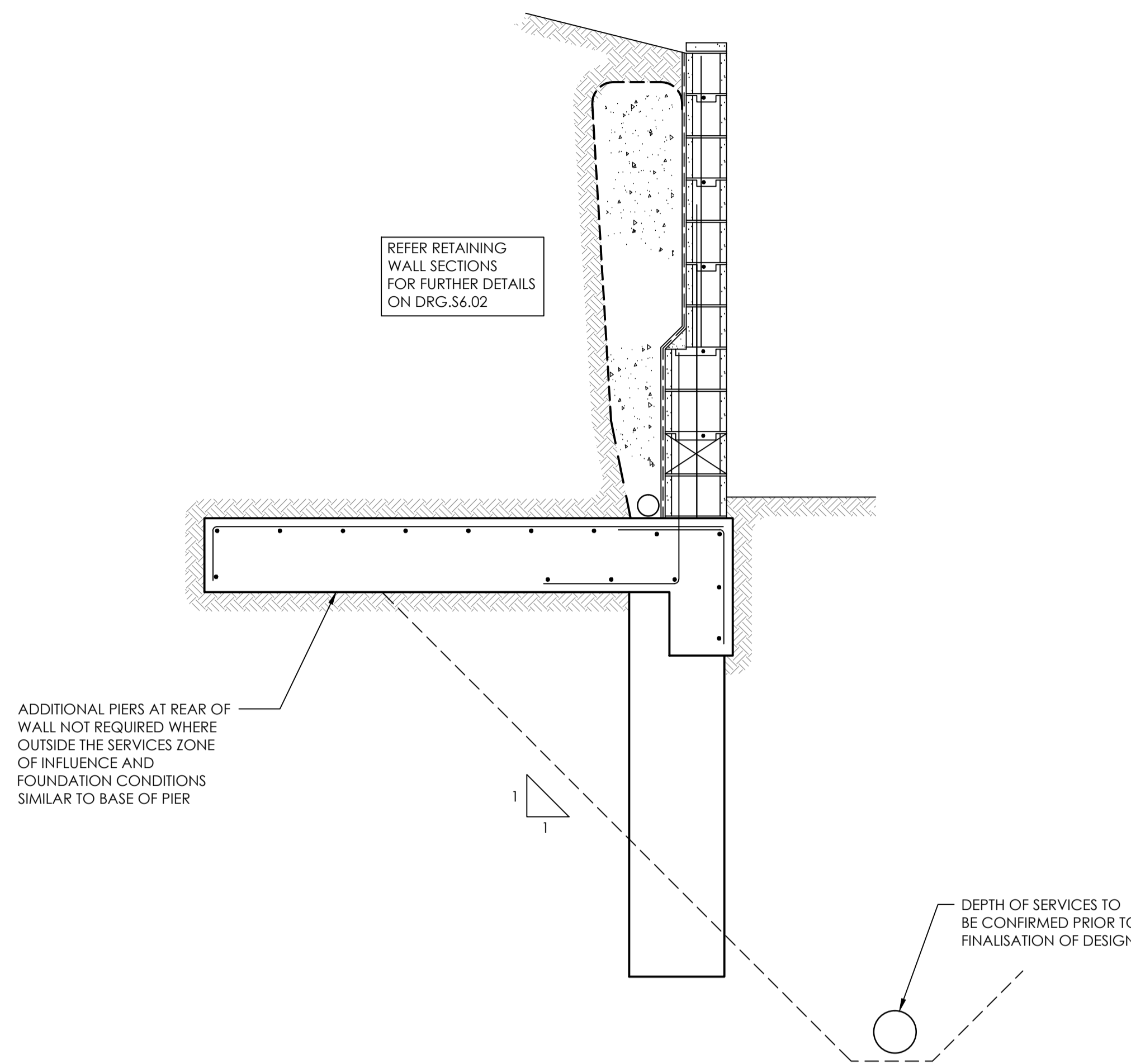

**BLOCKWORK RETAINING WALL TYPE B2  
WITHIN ZONE OF INFLUENCE OF SERVICES**  
SCALE 1:20 AT A1

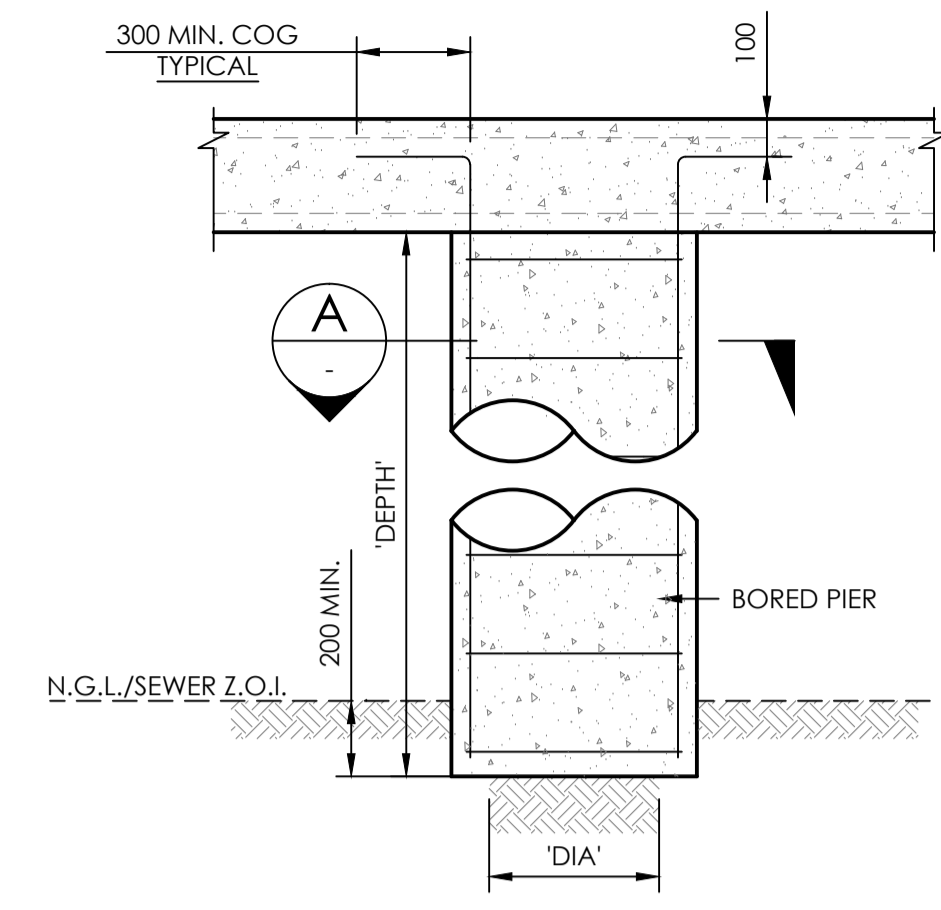

**AT LOCATIONS SHOWN ON PLAN  
TYPICAL BORED PIER DETAIL**  
N.T.S.

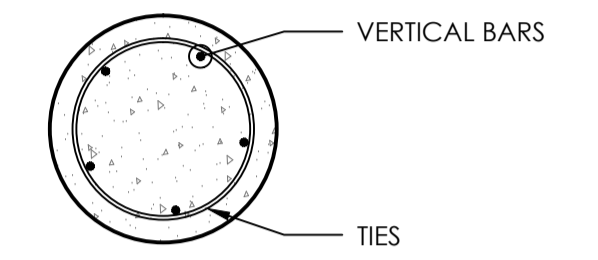

**DETAIL N.T.S.**  
TYPICAL BORED PIER

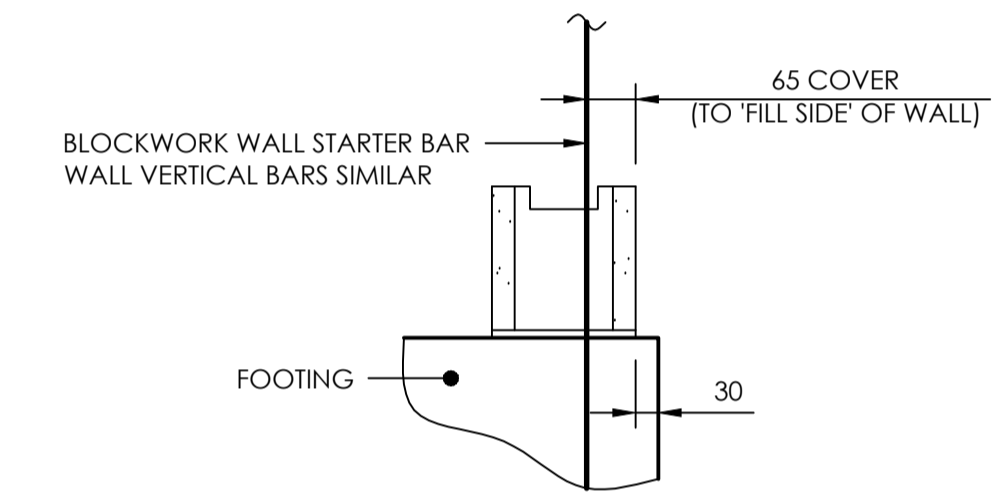

**TYPICAL WALL VERTICAL  
REINFORCEMENT DETAIL**  
N.T.S.

**NOTE:**  
ALL BLOCK CORES TO BE FULLY GROUTED.  
NOTES SHOWN ARE TYPICAL FOR ALL WALLS.  
ALL BASE KEYS TO BE POURED AGAINST UNDISTURBED NATURAL GROUND.

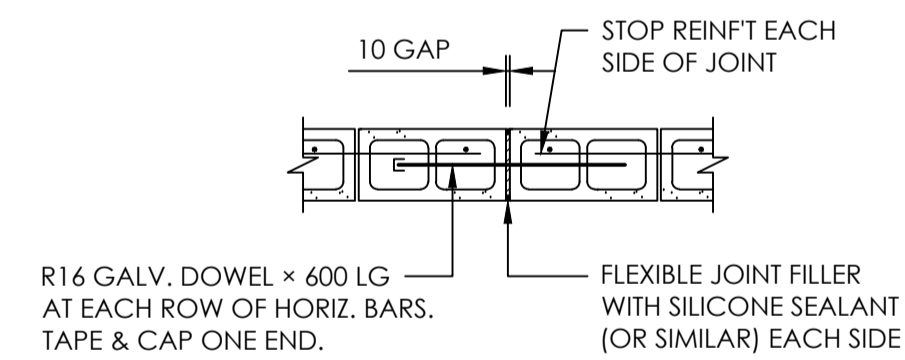

**VERTICAL JOINT DETAIL**  
PROVIDE VERTICAL JOINTS IN BLOCKWORK 8.0m MAX. CTS.

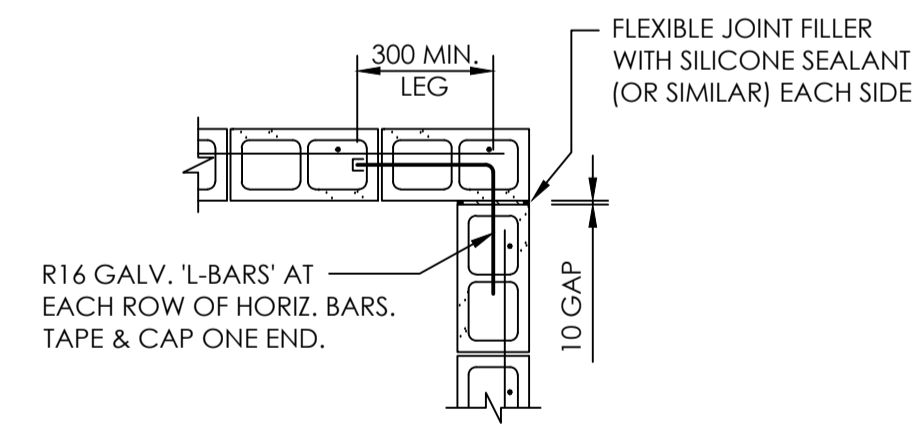

**CORNER DETAIL**

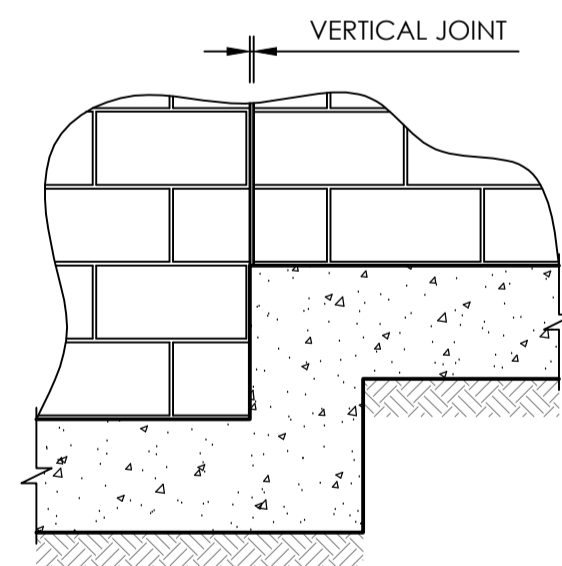

**TYPICAL VERTICAL JOINT AT STEP DETAIL**  
N.T.S.  
NOTE: VERTICAL JOINT LOCATIONS TO BE SPECIFIED DURING DETAILED DESIGN

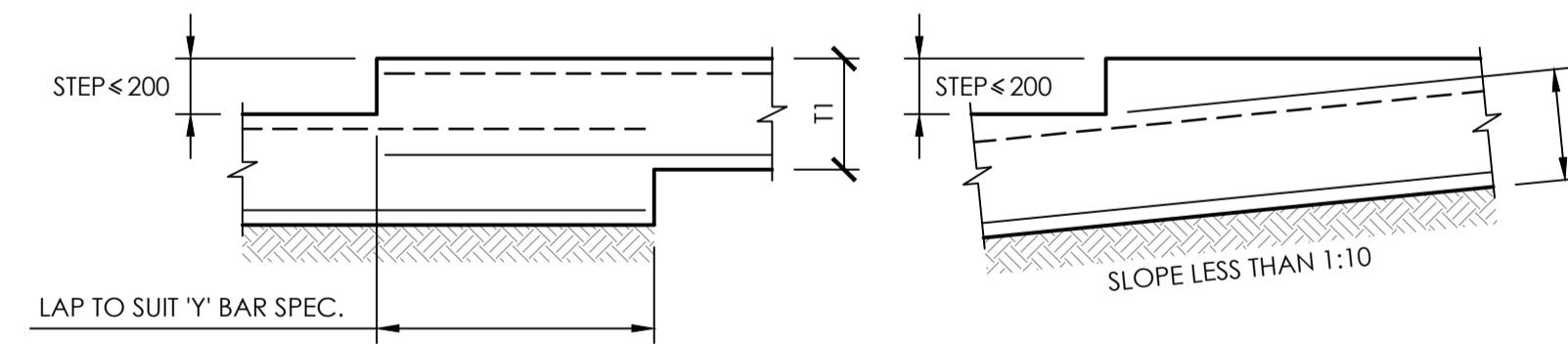

**FOOTING STEP DETAILS  
LESS THAN 2D**  
N.T.S.

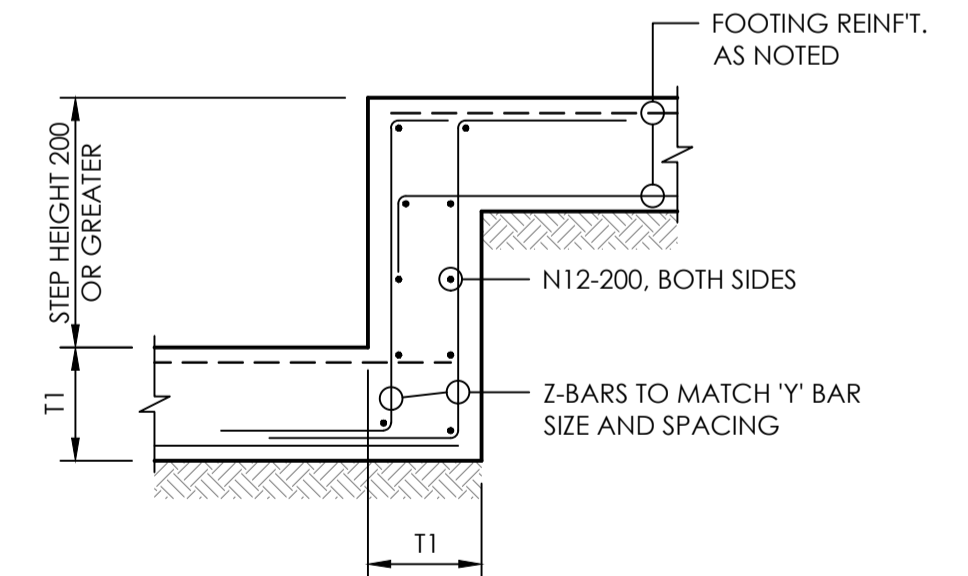

**STRIP FOOTING STEP 200mm OR GREATER**  
N.T.S.

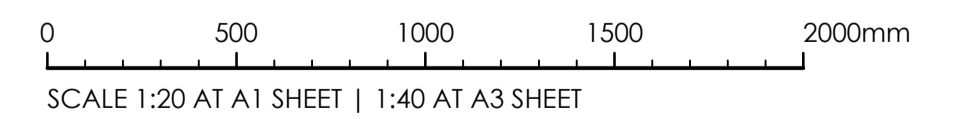

ISSUED FOR CLIENT REVIEW 07.02.24 A S.S.  
AMENDMENTS DATE ISSUE BY  
**NOT FOR CONSTRUCTION**

NORTH POINT U.N.O.  
ARCHITECT

CLIENT  
**AT&L AND ASSOCIATES**

PROJECT  
**TRANSPORT DEPOT**  
7A-11 RACECOURSE RD,  
5-9 FAUNCE ST & YOUNG ST, WEST GOSFORD

DESIGNED RO.O. DRAWN S.S. DATE 18.03.24 SIZE A1 CAD REF TX17790.00 - 501



**TRIAxIAL  
CONSULTING**  
COMPLEX PROBLEMS  
RESOLVED SIMPLY

1300 874 294 | TRIAXIAL.AU  
SUITE 12, LEVEL 14, 327 PITT STREET, SYDNEY NSW 2000  
PO BOX A203, SYDNEY SOUTH NSW 1235  
TO BE PRINTED IN COLOUR

DRAWING TITLE  
**RETAINING WALL DETAILS  
SHEET 2**

PROJECT No. TX17790.00 - S6.03 DRAWING No. ISSUE A